



# Chunghwa Picture Tubes, Ltd.

## Technical Specification

To	:	
Date	:	2009/05/04

*CPT TFT-LCD*  
**CLAA 185WA 03**

**ACCEPTED BY:**

APPROVED BY	CHECKED BY	PREPARED BY
		<b>Product Planning Management General Division</b>

### CHUNGHWA PICTUER TUBES, LTD.

No. 1, Huaying Rd., Sanho Tsun, Lungtan Shiang, Taoyuan, Taiwan, 325, R.O.C.  
TEL: +886-3-4805678 FAX: +886-3-4800589

Doc. No:	CLAA185WA03-SPEC-Ver.1-20090504	Issue Date:	2009/05/04
----------	---------------------------------	-------------	------------

## 1. OVERVIEW

CLAA185WA03 is 18.51" color TFT-LCD (Thin Film Transistor Liquid Crystal Display) module composed of LCD panel, driver ICs, control circuit and backlight. By applying 6bit+Hi-FRC digital data, 1366\*768, 16.7M-color images are displayed on the 18.51" diagonal screen. Input power voltage is 5.0V for LCD driving. Inverter for backlight is not included in this module. General specification are summarized in the following table:

ITEM	SPECIFICATION
Display Area(mm)	409.8(H)x230.4(V)
Number of Pixels	1366(H)x768(V)
Pixel Pitch(mm)	0.3(H)x0.3 (V)
Color Pixel Arrangement	RGB vertical stripe
Display Mode	normally white, TN
Number of Colors	16.7M(6 Bit+Hi-FRC)
Brightness(cd/m <sup>2</sup> )	250 cd/m <sup>2</sup> (Typ.) (Center point, Lamp current=7.5 mA)
Viewing Angle	170 / 160
Surface Treatment	Anti-glare, Hard coating(3H)
Power consumption(W)	14.5(typ)
Module Size(mm)	430.37(W)x254.6(H)x16.5(D)
Module Weight(g)	2000(typ)
Backlight Unit	CCFL, 2 tables, edge-light(top*1/bottom*1)

**2. ABSOLUTE MAXIMUM RATINGS**

ITEM	SYMBOL	MIN.	MAX.	UNIT	REMARK
Power Supply Voltage for LCD	VCC	0	6	V	
Lamp Voltage	VL	620	830	Vrms	
Lamp Current	ILO	3	8	mArms	*4). 7)
Lamp Frequency	FL	40	80	kHz	
static electricity	VESDt	-200	200	V	*5)
	VESDc	-8000	8000	V	
Operation Temperature	Top	0	50	°C	*1). 2). 3). 6)
Storage Temperature	Tstg	-20	60	°C	*1). 2). 3)
Delayed Discharge Time	TD	--	1	sec	*8)

[Note]

- 1). The relative temperature and humidity range are as below sketch, 90%RHMax.(Ta ≤ 40°C).
- 2). The maximum wet bulb temperature ≤ 39°C (Ta > 40°C) and without dewing.
- 3). If you use the product in a environment which over the definition of temperature and humidity too long to effect the result of eye-aching.
- 4). The life time of the lamp is related to the current of the lamp, so please according to the description of the “(b) backlight” on page 7.
- 5). Test Condition: IEC 1000-4-2  
 VESDt: Contact discharge to input connector; VESDc: Contact discharge to module
- 6). If you operate the product in normal temperature range, the center surface of panel should be under 60°C.
- 7). When lamp current is out of the absolute maximum range, the life will fall rapidly or shown unusual sign.  
 IL min 2mA only for test only, but we can't guarantee the lifetime and performance.
- 8). Delay lighting testing needs the volt above start voltage Vrms. Before the procedure tube needs typical lighting for 1 minute and stay in the temperature 25±2°C for 24 hours and then testing in the same condition in dark room.

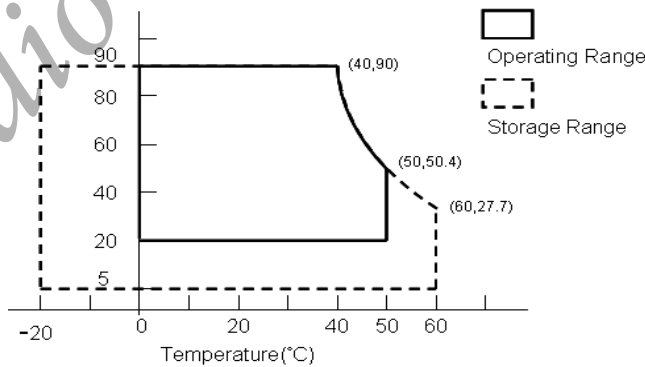

### 3. ELECTRICAL CHARACTERISTICS

#### (1).TFT-LCD

Ta=25°C

ITEM	SYMBOL	MIN	TYP	MAX	UNIT	Remark	
Power Supply Voltage for LCD	Vcc	4.5	5.0	5.5	V	*1)	
Power Supply Current for LCD	Icc	-	700	1000	mA	*2)	
Permissive Input Ripple Voltage	VRP	-	-	100	mVp-p	Vcc=5.0V	
Differential impedance	Zm	90	100	110	Ω		
Logic input voltage LVDS:IN+ , IN-	Common Mode Voltage	VCM	1.125	1.25	1.375	V	
	Differential Input Voltage	VID	250	350	450	mV	
	Threshold Voltage(High)	VTH	-	-	100	mV	*3)
	Threshold Voltage(Low)	VTL	-100	-	-	mV	
LCD Inrush Current	Inrush			3	A	*4)	
Power consumption	P		3.5	5.5	W	*2)	

[Note]

1).VCC-turn-on conditions:

$$0.5ms \leq t1 \leq 10ms \quad 1 \text{ sec} \leq t4$$

$$0 < t2 \leq 20ms \quad 200ms \leq t5$$

$$0 < t3 \leq 50ms \quad 200ms \leq t6$$

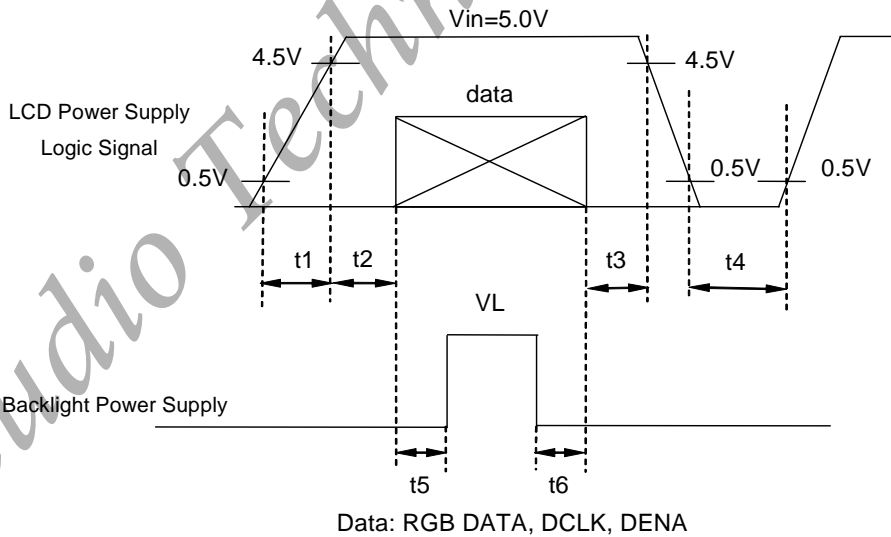

VCC-dip conditions:

- (1) When  $3.6V \leq V_{cc(min)} < 4.5V$ :  $t_d \leq 10\text{ ms}$
- (2) When  $V_{cc} < 3.6V$ , VCC-dip conditions should also follow the VCC-turn-on conditions.

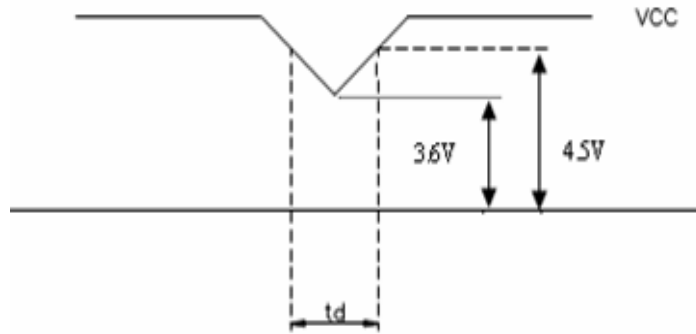

2). Typical current situation: 256 gray scale level, VCC=5.0V, Fh=47.28KHz, Fv=60Hz, Fclk=67.1 MHz.

Maximum current situation: CS Open scale level, VCC=5.0V, Fh=47.28KHz, Fv=60Hz, Fclk=67.1 MHz.

3).LVDS Signal definition:

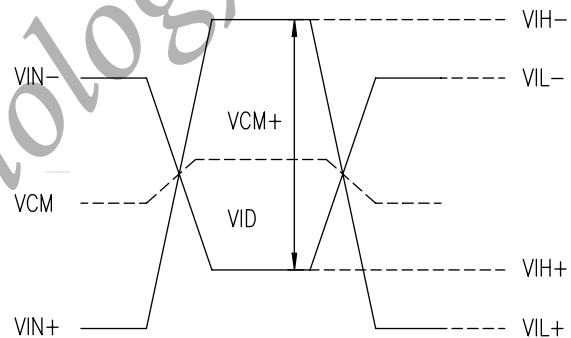
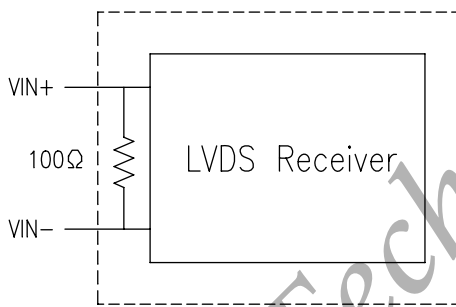

$$\begin{aligned}
 VID &= VIN_+ - VIN_- , \\
 \Delta VCM &= | VCM_+ - VCM_- | , \\
 \Delta VID &= | VID_+ - VID_- | , \\
 VID_+ &= | VIH_+ - VIH_- | , \\
 VID_- &= | VIL_+ - VIL_- | , \\
 VCM &= (VIN_+ + VIN_-) / 2 , \\
 VCM_+ &= (VIH_+ + VIH_-) / 2 , \\
 VCM_- &= (VIL_+ + VIL_-) / 2 ,
 \end{aligned}$$

VIN<sub>+</sub> = Positive differential DATA & CLK Input  
 VIN<sub>-</sub> = Negative differential DATA & CLK Input

4).Irush Measurement Condition

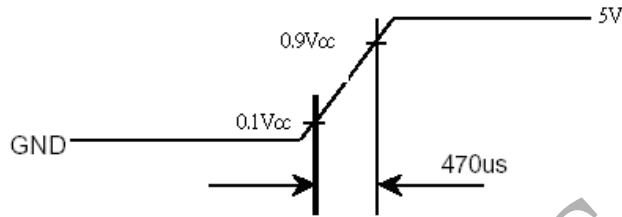
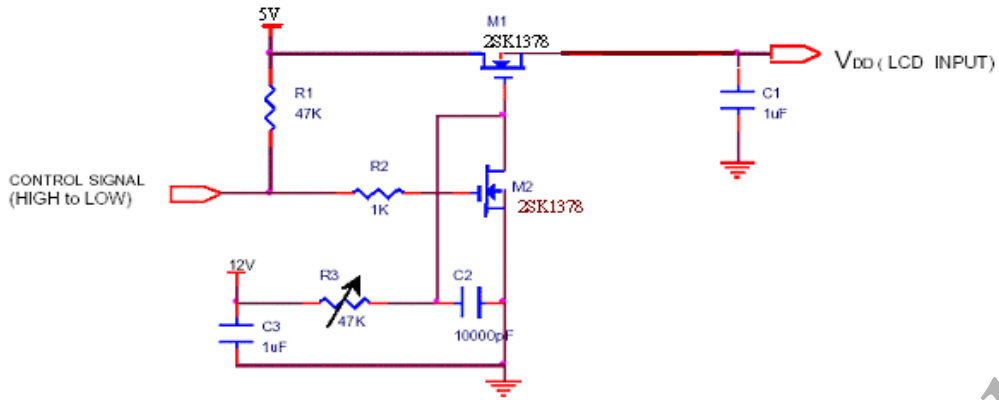

**(2).Backlight**

1. Electrical specification

ITEM	SYMBOL	MIN	TYP	MAX	UNIT	REMARK
B/L Voltage	VL	657	740	803	Vrms	IL=7.5mA Ta=25°C
B/L Current	IL	7	7.5	8	mArms	*1) *3) Ta=25°C
B/L operating current	ILO	3	7.5	8	mArms	*1) *3) Ta=25°C
B/L power consumption	WL	—	11	—	W	IL=7.5mA Ta=25°C
Inverter Frequency	FI	40	50	60	kHz	*2) Ta=25°C
Starting Lamp Voltage	VS	—	—	1700	Vrms	*9)Ta=0°C
		—	—	1400	Vrms	*9)Ta=25°C
PWM Dimming Ratio	—	20	-	100	%	*4)

2. Lamp life time

ITEM	ILO at 3.0 mA	ILO at 7.5 mA	ILO at 8.0 mA	UNIT	REMARK
Lamp life Time	Min. 50,000	Min. 40,000	Min. 30,000	hr	Continuous Operation *3)
Rated time (turn on/off)	—	Min. 10,000	—	time	*4)

[Note ] Measuring inverter Type : Hwa Youn , QF180V1.10S

If the waveform of light up-driving is asymmetric, the distribution of mercury inside the lamp tube will become unequally or will deplete the Ar gas in it. Then it may cause the abnormal phenomenon of lighting-up. Therefore, designers have to try their best to for fill the conditions under the inverter designing-stage as below:

- The degrees of unbalance :  $< 10\%$
- The ratio of wave height :  $< \sqrt{2} \pm 10\%$

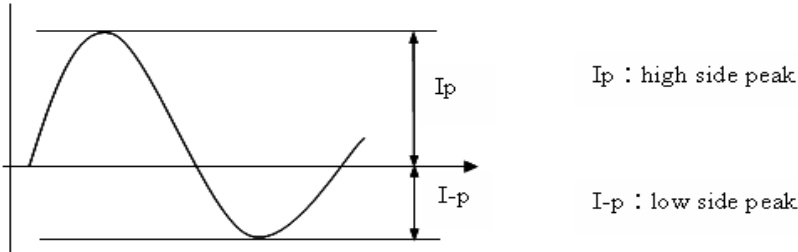

A : The degrees of unbalance =  $|Ip - I-p| / Irms \times 100 (\%)$   
 B : The ratio of wave height =  $Ip \text{ (or } I-p) / Irms$

The lamp work current( $I_{cyc}$ )of any period of light up-driving wave-form can not more than the maximum value of lamp standard work current(IL) , so the situation can not happened when designed Inverter.

[Note]  $I_{cyc}$  is a Cycle RMS value read by an oscilloscope

1) Lamp Current measurement method (The current meter is inserted in cold line)

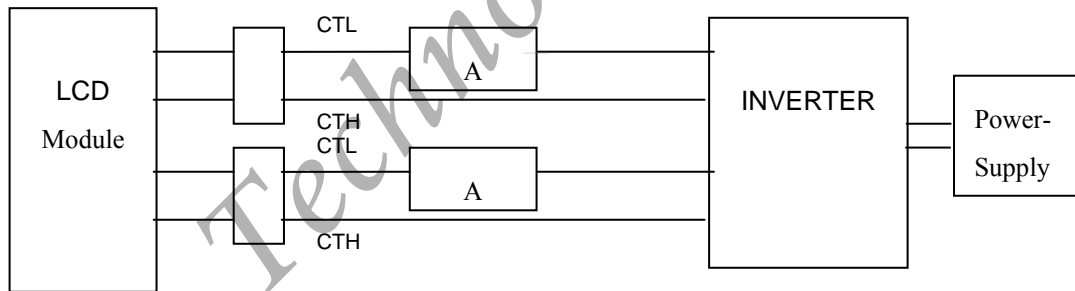

- 2) a. Frequency in this range can mala the characterisitcs of electric and optics maintain in +/- 10% except hue.
- b.If the lamp frequency can be maintain in 50~60KHz, the better charactristics of the electrical and the optical can be presented.
- c.If the operating frequency is 40~80 KHz, the life time and the reliability of the lamp will not be affect.
- d.Lamp frequency of inverter may produce interference with horizontal synchronous frequency,and this may cause horizontal beat on the display.Therefore, please adjust lamp frequency, and keep inverter as far from module as possible or use electronic shielding between inverter and module to avoid the interference.
- 3) It should be employed the inverter which has “Duty Dimming” , if ILO is less than 3mA.

- 4) The CCFL can work normally if the PWM Dimming Ratio range is from 20% to 100% and the lamp current is 7.5mA.
- 5) Definition of the lamp life time : Luminance (L) under 50% of specification starting lamp voltage or starting lamp voltage is more than 130% of the initial value
- 6) The condition of Turn-on and Turn-off operation is as below:
  - a. Lamp current is 7.5mA
  - b. Frequency is 30 sec. (on)/30 sec. (off)
  - c. Repeat it for 10 thousand times
  - d. The result of eye-aching of the lamp hue is normal, and can switch the lamp.It should not have motion fail when starting lamp voltage is lower than 130% of the initial value.
- 7) It is necessary to consider the maximal value when design inverter , in order to assure lighting.
- 8) The equation of power consumption  $WL=IL \times VL \times 2.(IL=7.5mA, Ta=25^{\circ}C)$
- 9) The voltage above VS should be applied to the lamps for more than 1 second for start-up.  
(Inverter open voltage must be more than lamp starting voltage.)

Studio Technology Co., Ltd.



#### 4. INTERFACE PIN CONNECTION

##### (1) CN1 (Data Signal and Power Supply)

Used connector: 093G30-B2001A (STARCONN) or compatible.

PIN NO.	SYMOBL	FUNCTION
1	NC	NC
2	NC	NC
3	NC	NC
4	GND	Power ground
5	RXIN0-	Negative LVDS differential data input(0)
6	RXIN0+	Positive LVDS differential data input(0)
7	GND	Power ground
8	RXIN1-	Negative LVDS differential data input(1)
9	RXIN1+	Positive LVDS differential data input(1)
10	GND	Power ground
11	RXIN2-	Negative LVDS differential data input(2)
12	RXIN2+	Positive LVDS differential data input(2)
13	GND	Power ground
14	RXCLKIN-	Negative LVDS differential clock input(clock)
15	RXCLKIN+	Positive LVDS differential clock input(clock)
16	GND	Power ground
17	RXIN3-	Negative LVDS differential data input(3)
18	RXIN3+	Positive LVDS differential data input(3)
19	GND	Power ground
20	NC	NC
21	NC	NC
22	NC	NC
23	GND	Power ground
24	GND	Power ground
25	GND	Power ground
26	VCC	Power supply input voltage(5.0 V)
27	VCC	Power supply input voltage(5.0 V)
28	VCC	Power supply input voltage(5.0 V)
29	VCC	Power supply input voltage(5.0 V)
30	VCC	Power supply input voltage(5.0 V)

##### (2) CN2, 3 (BACKLIGHT)

Backlight-side connector: CP0502SL090 (CVILUX) or compatible

xInverter-side connector: CP0502P1ML0-LF (CVILUX) or compatible

Pin No.	Symbol	Function
1	CTH	Power for CCFL
2	CTL	Power return for CCFL

### 5. INTERFACE TIMING

(1) Timing Specifications

		ITEM	SYMBOL	MIN	TYP	MAX	UNIT
LCD Timing	DCLK	Frequency	$f_{CLK}$	54.5	67.1	89.0	MHz
		Period	$t_{CLK}$	18.4	14.9	11.9	ns
	DENA	Horizontal Active Time	$t_{HA}$	1366	1366	1366	$t_{CLK}$
		Horizontal Blank Time	$t_{HB}$	34	54	74	$t_{CLK}$
		Horizontal Total Time	$t_H$	1406	1420	1460	$t_{CLK}$
		Vertical Active Time	$t_{VA}$	768	768	768	$t_H$
		Vertical Blank Time	$t_{VB}$	8	20	32	$t_H$
		Vertical Total Time	$t_V$	776	788	820	$t_H$
		Vertical Frame Rate	Fr	50	60	75	Hz

[Note]

- 1) DENA should always be positive polarity as shown in the timing specification.
- 2) CLK IN should appear during all blanking period,

(2) Timing Chart

a. Horizontal Timing

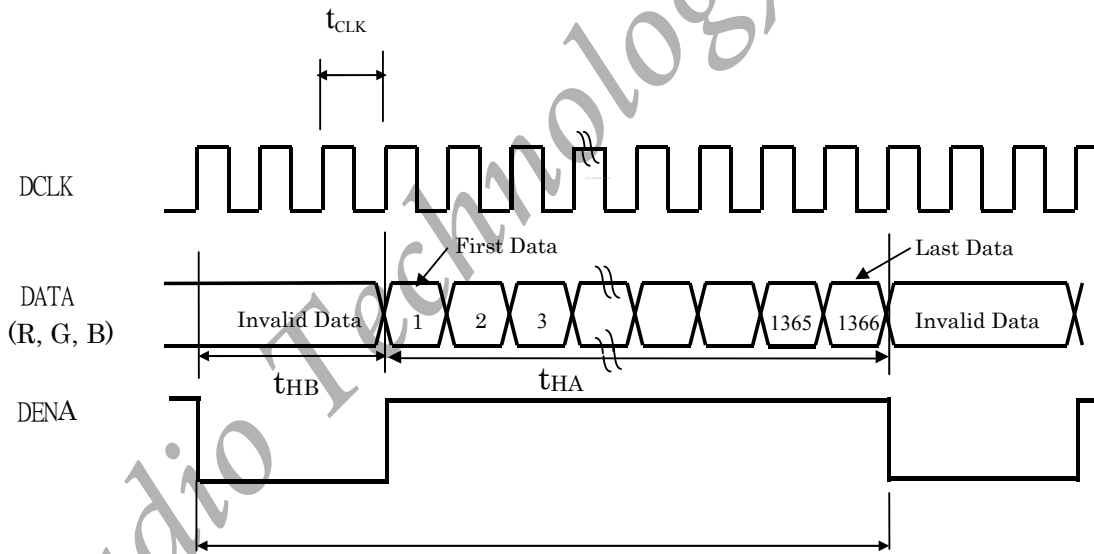

b. Vertical Timing

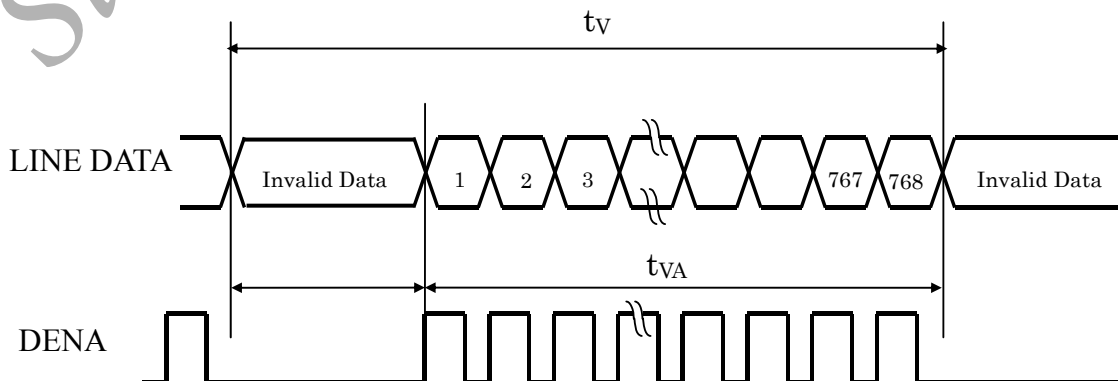

(3) LVDS DATA

(a) Timing Chart

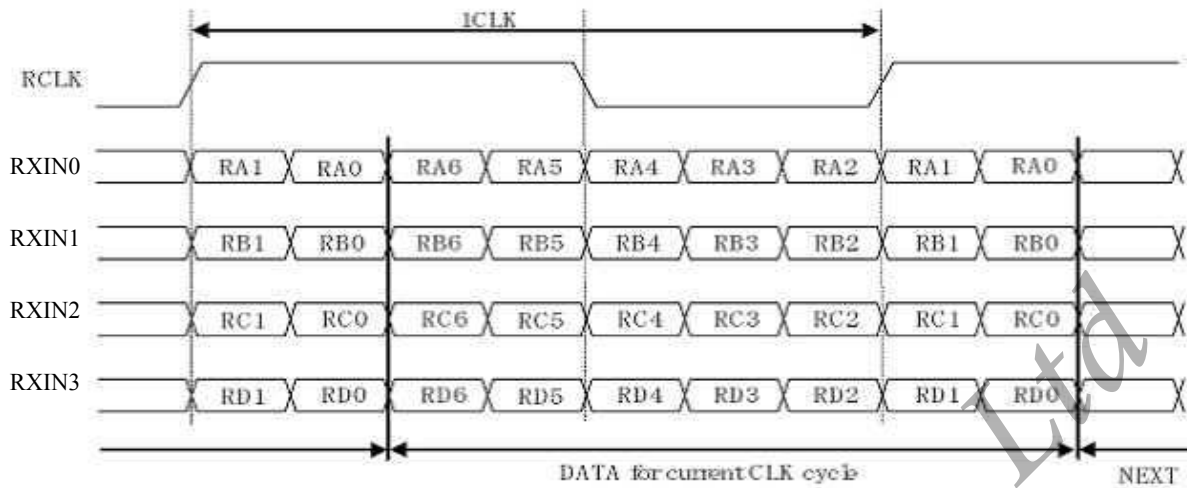

(b) Data mapping

Cell	Input Pin *)	Data(6bit + FRC)
RA0	TxIN0	RI0
RA1	TxIN1	RI1
RA2	TxIN2	RI2
RA3	TxIN3	RI3
RA4	TxIN4	RI4
RA5	TxIN6	RI5
RA6	TxIN7	GI0
RB0	TxIN8	GI1
RB1	TxIN9	GI2
RB2	TxIN12	GI3
RB3	TxIN13	GI4
RB4	TxIN14	GI5
RB5	TxIN15	BI0
RB6	TxIN18	BI1
RC0	TxIN19	BI2
RC1	TxIN20	BI3
RC2	TxIN21	BI4
RC3	TxIN22	BI5
RC4	TxIN24	RSVD
RC5	TxIN25	RSVD
RC6	TxIN26	DENA
RD0	TxIN27	RI6
RD1	TxIN5	RI7
RD2	TxIN10	GI6
RD3	TxIN11	GI7
RD4	TxIN16	BI6
RD5	TxIN17	BI7
RD6	TxIN23	(RSVD)
Ref-RCLK	TxCLKIN	DCLKI

\*) : DS90C383MTD

(4) Color Data Assignment

COLOR	INPUT DATA	R DATA								G DATA								B DATA							
		R7 MSB	R6	R5	R4	R3	R2	R1	R0 LSB	G7 MSB	G6	G5	G4	G3	G2	G1	G0 LSB	B7 MSB	B6	B5	B4	B3	B2	B1	B0 LSB
BASIC COLOR	BLACK	0	0	0	0	0	0	0	0	0	0	0	0	0	0	0	0	0	0	0	0	0	0	0	0
	RED(255)	1	1	1	1	1	1	1	1	0	0	0	0	0	0	0	0	0	0	0	0	0	0	0	
	GREEN(255)	0	0	0	0	0	0	0	0	1	1	1	1	1	1	1	0	0	0	0	0	0	0	0	
	BLUE(255)	0	0	0	0	0	0	0	0	0	0	0	0	0	0	0	1	1	1	1	1	1	1	1	
	CYAN	0	0	0	0	0	0	0	0	1	1	1	1	1	1	1	1	1	1	1	1	1	1	1	
	MAGENTA	1	1	1	1	1	1	1	1	0	0	0	0	0	0	0	1	1	1	1	1	1	1	1	
	YELLOW	1	1	1	1	1	1	1	1	1	1	1	1	1	1	1	0	0	0	0	0	0	0	0	
	WHITE	1	1	1	1	1	1	1	1	1	1	1	1	1	1	1	1	1	1	1	1	1	1	1	
RED	RED(0)	0	0	0	0	0	0	0	0	0	0	0	0	0	0	0	0	0	0	0	0	0	0		
	RED(1)	0	0	0	0	0	0	0	1	0	0	0	0	0	0	0	0	0	0	0	0	0	0		
	RED(2)	0	0	0	0	0	0	1	0	0	0	0	0	0	0	0	0	0	0	0	0	0	0		
	RED(254)	1	1	1	1	1	1	1	0	0	0	0	0	0	0	0	0	0	0	0	0	0	0		
	RED(255)	1	1	1	1	1	1	1	1	0	0	0	0	0	0	0	0	0	0	0	0	0	0		
GREEN	GREEN(0)	0	0	0	0	0	0	0	0	0	0	0	0	0	0	0	0	0	0	0	0	0	0		
	GREEN(1)	0	0	0	0	0	0	0	0	0	0	0	0	0	0	1	0	0	0	0	0	0	0		
	GREEN(2)	0	0	0	0	0	0	0	0	0	0	0	0	0	1	0	0	0	0	0	0	0	0		
	GREEN(254)	0	0	0	0	0	0	0	1	1	1	1	1	1	1	0	0	0	0	0	0	0	0		
	GREEN(255)	0	0	0	0	0	0	0	1	1	1	1	1	1	1	1	0	0	0	0	0	0	0		
BLUE	BLUE(0)	0	0	0	0	0	0	0	0	0	0	0	0	0	0	0	0	0	0	0	0	0	0		
	BLUE(1)	0	0	0	0	0	0	0	0	0	0	0	0	0	0	0	0	0	0	0	0	0	1		
	BLUE(2)	0	0	0	0	0	0	0	0	0	0	0	0	0	0	0	0	0	0	0	0	1	0		
	BLUE(254)	0	0	0	0	0	0	0	0	0	0	0	0	0	0	1	1	1	1	1	1	1	0		
	BLUE(255)	0	0	0	0	0	0	0	0	0	0	0	0	0	0	1	1	1	1	1	1	1	1		

[Note]

- 1) Definition of gray scale: Color (n): n indicates gray scale level.  
Higher n means brighter level.
- 2) Data: 1-High, 0-Low.
- 3) This assignment is applied to both odd and even data.

(5) Color Data Assignment

D(1,1)	D(2,1)	--	D(X,1)	--	D(1365,1)	D(1366,1)
D(1,2)	D(2,2)	--	D(X,2)	--	D(1365,2)	D(1366,2)
		+	..	+		
D(1,Y)	D(2,Y)	--	D(X,Y)	--	D(1365,Y)	D(1366,Y)
		+	..	+		
D(1,767)	D(2, 767)	--	D(X, 767)	--	D(1365,767)	D(1366,767)
D(1,768)	D(2, 768)	--	D(X, 768)	--	D(1365,768)	D(1366,768)

### 6. BLOCK DIAGRAM

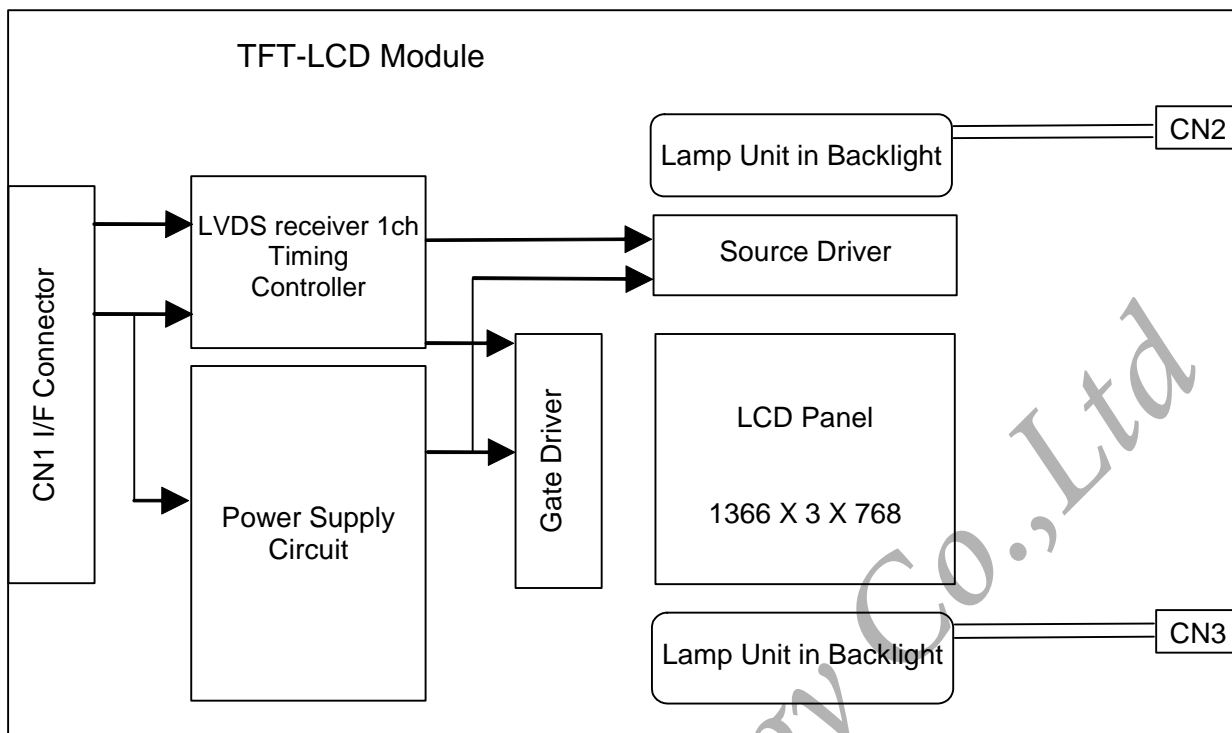

Lamp Unit in Backlight

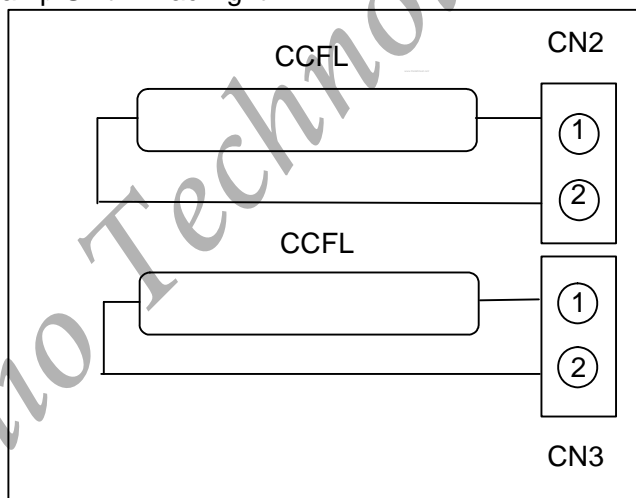

### 7. MECHANICAL SPECIFICATION

(1) Front side (Tolerance is  $\pm 0.5\text{mm}$  unless noted)

Unit: mm

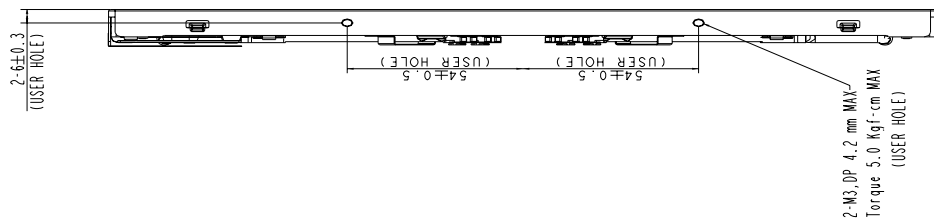
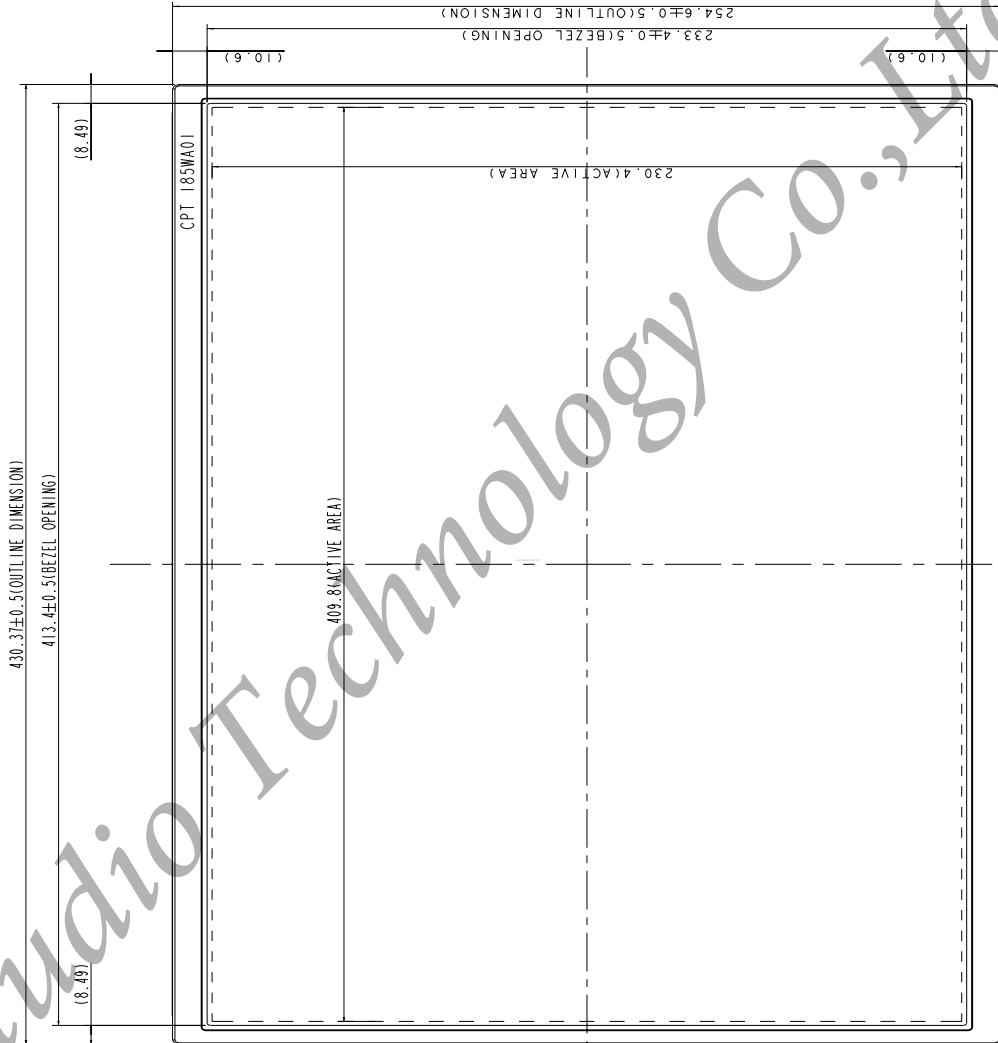
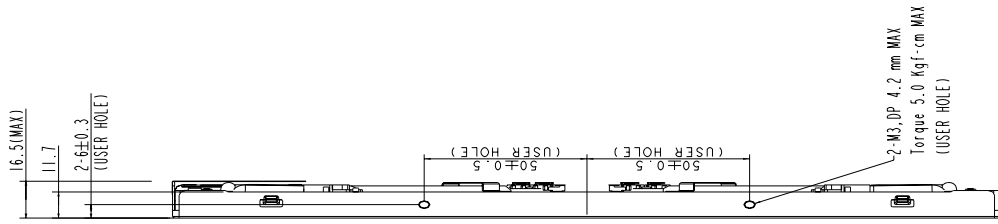

(2) Rear side (Tolerance is  $\pm 0.5\text{mm}$  unless noted)

Unit: mm

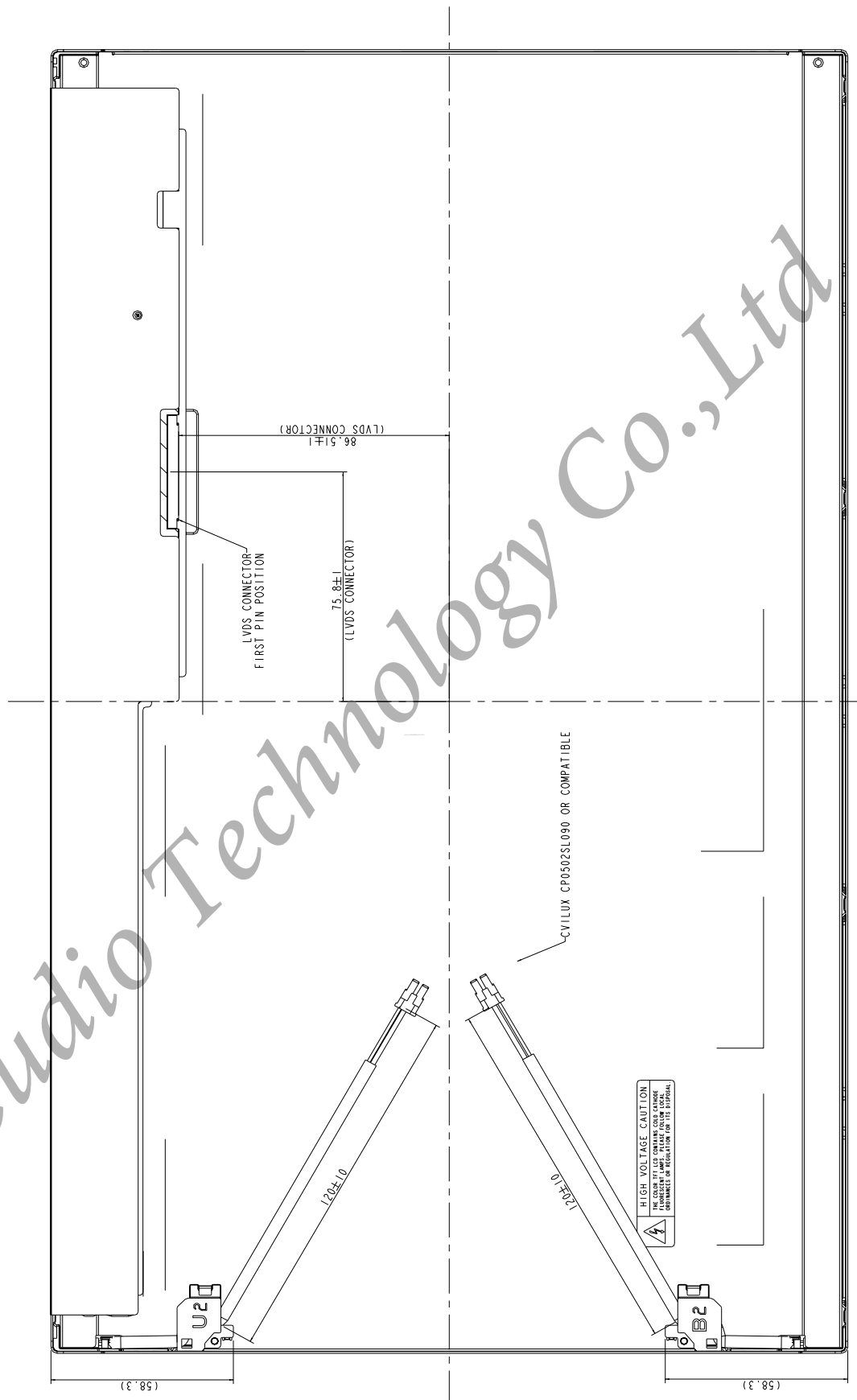

8. OPTICAL CHARACTERISTICS

Ta=25°C , VCC=5.0V

ITEM	SYMBOL	CONDITION	min	typ	max	UNIT	REMARK	
Contrast Ratio	CR	$\theta = \psi = 0^\circ$	700	1000	--	--	*1) 2)	
Luminance(CEN)	L	$\theta = \psi = 0^\circ$	200	250	--	cd/m <sup>2</sup>	*1) 3)	
9P Uniformity	$\Delta L$	$\theta = \psi = 0^\circ$	75	--	--	%	*1) 3)	
Response Time	Tr	$\theta = \psi = 0^\circ$	--	5	8	ms	*5)	
	Tf	$\theta = \psi = 0^\circ$	--			ms		
Crosstalk	CT	$\theta = \psi = 0^\circ$	0	--	1	%	*6)	
Viewing Angle	Horizontal	$\Psi(L/R)$	$CR \geq 10$	150	170	--	*4)	*3)
	Vertical	$\theta(U/D)$		140	160	--		
Color Coordinates	White	X	$\theta = \psi = 0^\circ$	0.283	0.313	0.343	*3)	*2)
		Y		0.299	0.329	0.359		
	Red	X		0.620	0.650	0.680		
		Y		0.305	0.335	0.365		
	Green	X		0.252	0.282	0.312		
		Y		0.586	0.616	0.646		
	Blue	X		0.116	0.146	0.176		
		Y		0.055	0.085	0.115		
Gamma	$\gamma$	VESA	2.0	2.2	2.4	--	*7)	

[Note]

1) All optical specification condition:

- (1) Equipment: Color coordinate and color gamut are measured by CS-1000, and all the other items are measured by BM-5A (TOPCON).
- (2) Condition: IL=7.5 (each lamp) mA, Inverter: Hwa Youn , QF180V1.10S, Frequency=50 kHz.
- (3) The LCD module should be turn-on to a stable luminance level to be reached. The measurement should be executed after lighting Backlight for 20 minutes and in a dark room.

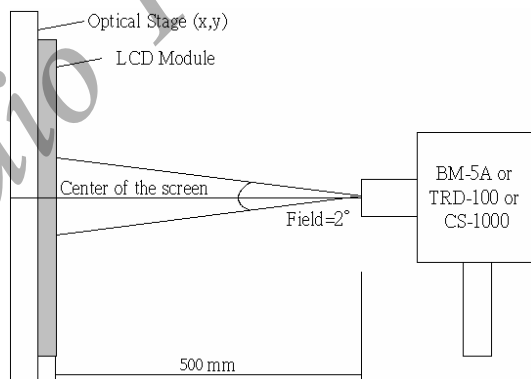

2). Definition of Contrast Ratio:

$$CR = \text{ON (White) Luminance} / \text{OFF (Black) Luminance}$$



3).Definition of Luminance and Luminance uniformity:

Center Luminance: measuring the luminance of the point no. 5

Average Luminance: measuring average luminance of points no.1-no.9

Uniformity:  $\Delta L = [L (\text{Min})/L (\text{Max})] \times 100 \%$

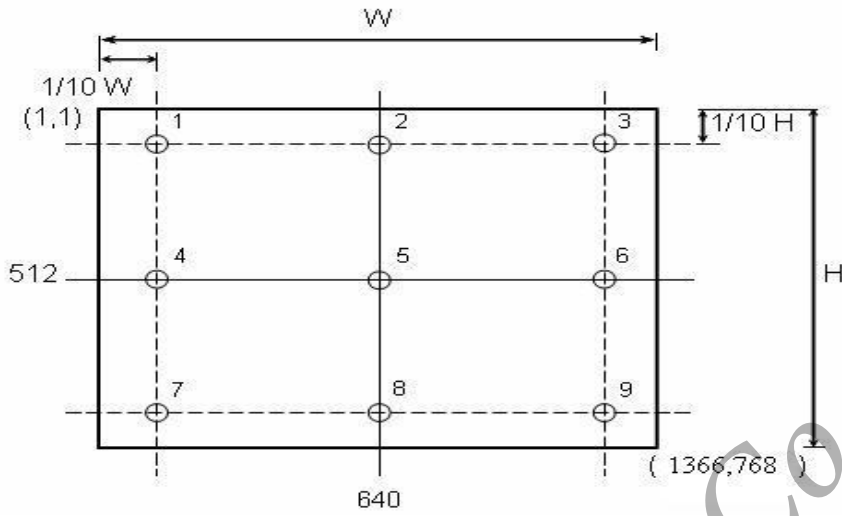

4).Definition of Viewing Angle ( $\theta, \psi$ ):

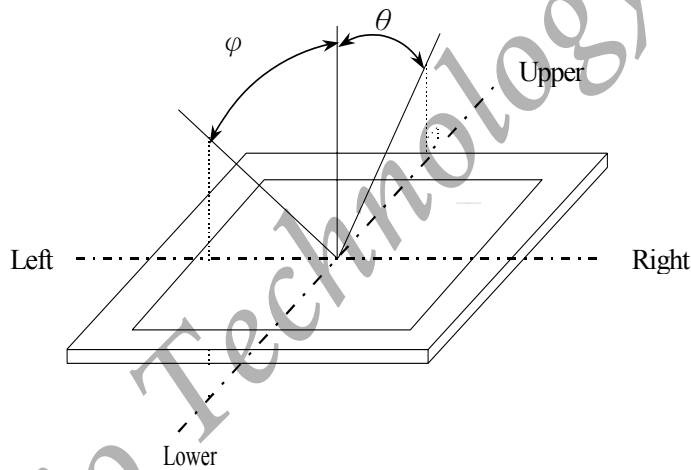

5) Definition of Response Time:

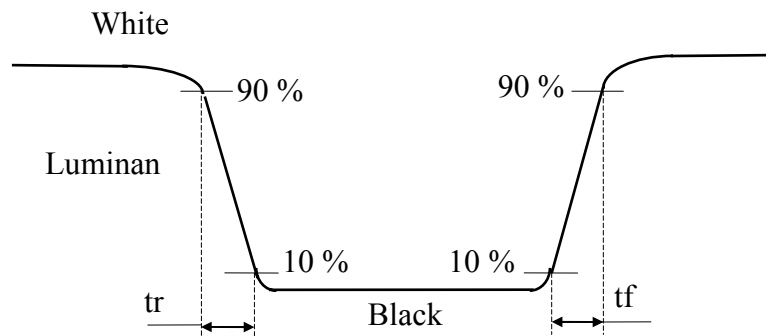

6) Definition of crosstalk:

$$CT = | Y_B - Y_A | / Y_A \times 100 (\%)$$

$Y_A$ : The luminance of measured position at pattern A

$Y_B$ : The luminance of measured position at pattern B with Gray level 0

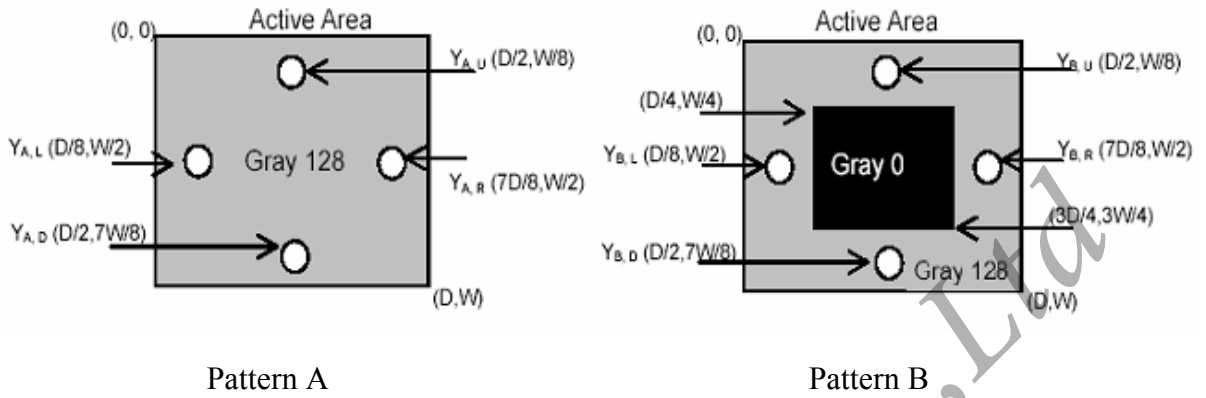

7) Definition of Gamma ( $\gamma$ ), follow VESA standard sampling every 16 gray level (0, 16, 32, ..., 224, 240, 255)

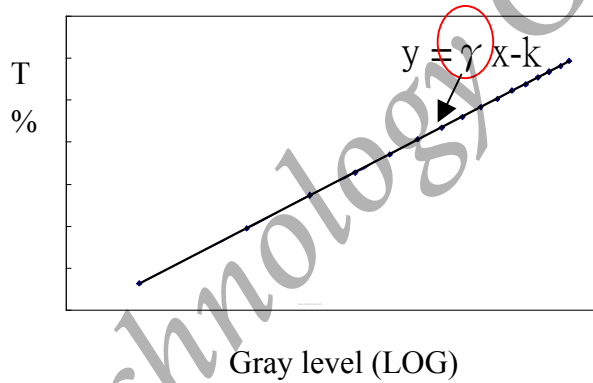

## 9. RELIABILITY TEST CONDITIONS

### (1) Temperature and Humidity

TEST ITEMS	CONDITIONS
HIGH TEMPERATURE HIGH HUMIDITY OPERATION	50°C ; 90%RH; 240h (No condensation)
HIGH TEMPERATURE HIGH HUMIDITY STORAGE	60°C ; 90%RH;48h (No condensation)
HIGH TEMPERATURE OPERATION	50°C ; 240h
HIGH TEMPERATURE STORAGE	60°C ; 240h
LOW TEMPERATURE OPERATION	0°C ; 240h
LOW TEMPERATURE STORAGE	-20°C ; 240h
THERMAL SHOCK	BETWEEN -20°C(1hr)AND 60°C(1hr); 100 CYCLES

### (2) Shock & Vibration

ITEMS	CONDITIONS
SHOCK (NON-OPERATION)	Shock level:1470m/s <sup>2</sup> (150G) Waveform: half sinusoidal wave, 2ms Number of shocks: 1/2 shock input in each direction of three mutually perpendicular axes for a total of six shock inputs
VIBRATION (NON-OPERATION)	Vibration level: 9.8m/s <sup>2</sup> (1.0G) zero to peak Waveform: sinusoidal Frequency range: 5 to 500 Hz Frequency sweep rate: 0.5 octave/min Duration: one sweep from 5 to 500Hz in each of three mutually perpendicular axis(each x,y,z axis: 1 hour, total 3 hours)

### (3) ESD

POSITION	CONDITION( MDL turn off)
Connector	1. 200 pF , 0 Ω , ±250 V 2. contact mode for each pin
Module	1. 150 pF , 330 Ω , ±15K V 2. Air mode, test 25 times for each test point 3. Contact mode, 25 times for each test point

### (4) Low Pressure test

TEST ITEM	CONDITION
Low Pressure test(storage)	260HPa (30000 ft.) ; 24 Hr

### (5) Judgment standard

The judgment of the above test should be made as follow:

Pass: Normal display image with no obvious non-uniformity and no line defect. Partial transformation of the module parts should be ignored.

Fail: No display image, obvious non-uniformity, or line defects.

## 10. HANDLING PRECAUTIONS FOR TFT-LCD MODULE

Please pay attention to the followings in handling- TFT-LCD products;

### (1) ASSEMBLY PRECAUTION

- 1) Please use the mounting hole on the module side in installing and do not beading or wrenching LCD in assembling. And please do not drop, bend or twist LCD module in handling.
- 2) Please design display housing in accordance with the following guide lines.
  - a) Housing case must be destined carefully so as not to put stresses on LCD all sides and not to wrench module. The stresses may cause non-uniformity even if there is no non-uniformity statically.
  - b) Keep sufficient clearance between LCD module back surface and housing when the LCD module is mounted. Approximately 1.0 mm of the clearance in the design is recommended taking into account the tolerance of LCD module thickness and mounting structure height on the housing.
  - c) When some parts, such as, FPC cable and ferrite plate, are installed underneath the LCD module, still sufficient clearance is required, such as 0.5mm. This clearance is, especially, to be reconsidered when the additional parts are implemented for EMI countermeasure.
  - d) Design the inverter location and connector position carefully so as not to give stress to lamp cable, or not to interface the LCD module by the lamp cable.
  - e) Keep sufficient clearance between LCD module and the others parts, such as inverter and speaker so as not to interface the LCD module. Approximately 1.0mm of the clearance in the design is recommended.
- 3) Please do not push or scratch LCD panel surface with any-thing hard. And do not soil LCD panel surface by touching with bare hands. (Polarizer film, surface of LCD panel is easy to be flawed.)
- 4) Please do not press any parts on the rear side such as source TCP, gate TCP, control circuit board and FPCs during handling LCD module. If pressing rear part is unavoidable, handle the LCD module with care not to damage them.
- 5) Please wipe out LCD panel surface with absorbent cotton or soft cloth in case of it being soiled.
- 6) Please wipe out drops of adhesives like saliva and water on LCD panel surface immediately. They might damage to cause panel surface variation and color change.
- 7) Please do not take a LCD module to pieces and reconstruct it. Resolving and reconstructing modules may cause them not to work well.
- 8) Please do not touch metal frames with bare hands and soiled gloves. A color change of the metal frames can happen during a long preservation of soiled LCD modules.
- 9) Please pay attention to handling lead wire of backlight so that it is not tugged in connecting with inverter.

### (2) OPERATING PRECAUTIONS

- 1) Please be sure to turn off the power supply before connecting and disconnecting signal input cable.
- 2) Please do not change variable resistance settings in LCD module. They are adjusted to the

most suitable value. If they are changed, it might happen LCD does not satisfy the characteristics specification.

- 3) Please consider that LCD backlight takes longer time to become stable of radiation characteristics in low temperature than in room temperature.
- 4) A condensation might happen on the surface and inside of LCD module in case of sudden change of ambient temperature.
- 5) Please pay attention to displaying the same pattern for very long time. Image might stick on LCD. If then, time going on can make LCD work well.
- 6) Please obey the same caution descriptions as ones that need to pay attention to ordinary electronic parts.

### **(3) PRECAUTIONS WITH ELECTROSTATICS**

- 1) This LCD module use CMOS-IC on circuit board and TFT-LCD panel, and so it is easy to be affected by electrostatics. Please be careful with electrostatics by the way of your body connecting to the ground and so on.
- 2) Please remove protection film very slowly on the surface of LCD module to prevent from electrostatics occurrence.

### **(4) STORAGE PRECAUTIONS**

- 1) When you store LCDs for a long time, it is recommended to keep the temperature between 0°C ~40°C without the exposure of sunlight and to keep the humidity less than 90%RH.
- 2) Please do not leave the LCDs in the environment of high humidity and high temperature such as 60°C 90%RH.
- 3) Please do not leave the LCDs in the environment of low temperature; below -20°C.

### **(5) SAFETY PRECAUTIONS**

- 1) When you waste LCDs, it is recommended to crush damaged or unnecessary LCDs into pieces and wash them off with solvents such as acetone and ethanol, which should later be burned.
- 2) If any liquid leaks out of a damaged-glass cell and comes in contact with the hands, wash off thoroughly with soap and water.

### **(6) OTHERS**

- 1) A strong incident light into LCD panel might cause display characteristics' changing inferior because of polarizer film, color filter, and other materials becoming inferior. Please do not expose LCD module direct sunlight and strong UV rays.
- 2) Please pay attention to a panel side of LCD module not to contact with other materials in preserving it alone.
- 3) For the. Packaging box, please pay attention to the followings:
  - a) Packaging box and inner case for LCD are designed to protect the LCDs from the damage or scratching during transportation. Please do not open except picking LCDs up from the box.
  - b) Please do not pile them up more than 5 boxes. (They are not designed so.) And please do not turn over.
  - c) Please handle packaging box with care not to give them sudden shock and vibrations. And

also please do not throw them up.

d) Packing box and inner case for LCDs are made of cardboard. So please pay attention not to get them wet. (Such like keeping them in high humidity or wet place can occur getting them wet.)

Studio Technology Co., Ltd