



SmarterGlass

state-of-the-art display solutions

www.smarterglass.com
978 997 4104
sales@smarterglass.com

ISSUED DATE : 2008-02-13

SAMSUNG TFT-LCD PRODUCT INFORMATION

MODEL : LTM270CS01

Application Engineering Part 1, HD LCD Division

Samsung Electronics Co . , LTD.



SAMSUNG TFT-LCD

Contents

General Description	(3)
1. Absolute Maximum Ratings	(4)
2. Optical Characteristics	(6)
3. Electrical Characteristics	(12)
3.1 TFT LCD Module	
3.2 Back Light Unit	
4. Block Diagram	(17)
4.1 TFT LCD Module	
4.2 Back Light Unit	
5. Input Terminal Pin Assignment	(18)
5.1.1 Input Signal & Power	
5.1.2 Inverter input connector	
5.2 Back Light Unit	
5.3 Input Signals, Basic Display Colors and Gray Scale of Each Color	
6. Interface Timing	(23)
6.1 Timing Parameters (DE only mode)	
6.2 Timing Diagrams of interface Signal (DE only mode)	
6.3 Power ON/OFF Sequence	
6.4 Inverter Power sequence	
6.5 VDD Power Dip Condition	
7. Outline Dimension	(28)
8. General Precaution	(31)
8.1 Handling	
8.2 Storage	
8.3 Operation	
8.4 Others	

General Description

Description

LTM270CS01 is a color active matrix liquid crystal display (LCD) that uses amorphous silicon TFT (Thin Film Transistor) as switching components. This model is composed of a TFT LCD panel, a driver circuit and a back light unit. The resolution of a 27.0" is 1920 x 1200 and this model can display up to 1,074 millions colors.

Features

- High contrast ratio, high aperture structure, High color gamut
- S-PVA (Super Patterned Vertical Alignment) mode
- Wide viewing angle
- High speed response
- WUXGA (1920 x 1200 pixels) resolution
- Direct Type B/L Unit with 8 U-Type CCFLs (Cold Cathod Fluorescent Lamp)
- DE (Data Enable) mode
- LVDS (Low Voltage differential Signaling) interface (2pixel/clock)
- RoHS compliance
- Pb-free compliance

Applications

- Workstation & desktop monitors
 - Display terminals for AV application products
 - Monitors for industrial machine
- * If the module is used to other applications besides the above, please contact SEC in advance.

General Information

Items	Specification	Unit	Note
Pixel Pitch	0.303 x 0.303	mm	
Active Display Area	581.76(H) x 363.6(V)	mm	
Surface Treatment	Haze 44%, Hard coating 3H		
Display Colors	1,074M	colors	
Number of Pixels	1920 x 1200	pixel	
Pixel Arrangement	RGB vertical stripe		
Display Mode	Normally Black		
Luminance of White	400(Typ.)	cd/m ²	

Mechanical Information

Item		Min.	Typ.	Max.	Unit	Note
Module size	Horizontal (H)	-	615.8	-	mm	w/o inverter ass'y
	Vertical (V)	-	397.6	-	mm	
	Depth (D)	-	41.6	-	mm	w/ inverter ass'y
Weight		-	-	-	g	LCD module only
		-	-	3,800	g	w/ Inverter assembly

Note (1) Mechanical tolerance is $\pm 0.5\text{mm}$ unless there is a special comment.

1. Absolute Maximum Ratings

If the condition exceeds maximum ratings, it can cause malfunction or unrecoverable damage to the device.

Item	Symbol	Min.	Max.	Unit	Note
Power Supply Voltage	V_{DD}	GND-0.5	6.5	V	
Data Signal	V_{sig}	-	5	V	
Storage temperature	T_{STG}	-20	60	°C	(1)
Glass surface temperature (Operation)	T_{OPR}	0	50	°C	
Shock (non - operating)	S_{nop}	-	50	G	(2)
Vibration (non - operating)	V_{nop}	-	1.5	G	(3)

Note (1) $T_a = 25 \pm 2 \text{ }^\circ\text{C}$

- (1) Temperature and relative humidity range are shown in the figure below.
 - a. 90 % RH Max. ($T_a \leq 39\text{ }^\circ\text{C}$)
 - b. Maximum wet-bulb temperature at $39\text{ }^\circ\text{C}$ or less. ($T_a \leq 39\text{ }^\circ\text{C}$)
 - c. No condensation
- (2) 11ms, sine wave, one time for $\pm X$, $\pm Y$, $\pm Z$ axis
- (3) 10-300 Hz, Sweep rate 10min, 30min for X,Y,Z axis

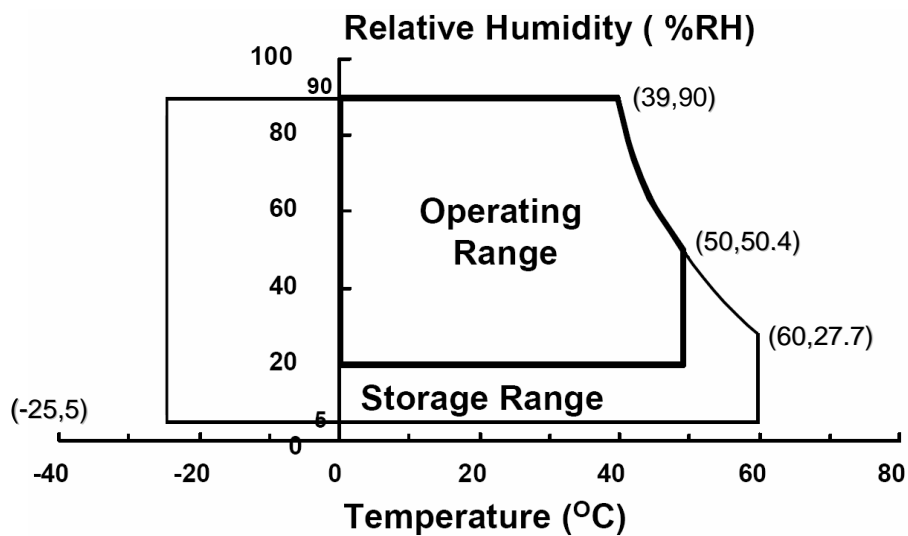

Fig. Temperature and Relative humidity range

2. Optical Characteristics

The optical characteristics should be measured in a dark room or equivalent.

Measuring equipment : TOPCON BM-7,SPECTRORADIOMETER SR-3

(Ta = 25 ± 2°C, VDD=5V, fv= 60Hz, fDCLK=77MHz, IL = (6.0)mArms)

Item		Symbol	Condition	Min.	Typ.	Max.	Unit	Note						
Contrast Ratio (Center of screen)		C/R	Normal $\theta_{L,R}=0$ $\theta_{U,D}=0$ Viewing Angle	1,000	1,300	-		(3) SR-3						
				2,000	3,000	-		w/ SIC						
Response Time	On/Off	Tr + Tf		-	16	20	msec	(5) BM-7						
	G-To-G	T _{G-G,AVG}		-	6	-	msec	BM-7						
Luminance of White (Center of screen)		Y _L		(350)	400	-	cd/m ²	(6) SR-3						
Color Chromaticity (CIE 1931)	Red	Rx		-0.030	+0.030	0.675								
		Ry				0.318								
	Green	Gx				0.189								
		Gy				0.704								
	Blue	Bx				0.147								
		By	0.069											
	White	Wx	0.313											
		Wy	0.329			(7),(8)								
	Color Chromaticity (CIE 1976)	Red	Ru'			-				-	0.494	-		SR-3
			Rv'								0.524			
Green		Gu'	0.068											
		Gv'	0.572											
Blue		Bu'	0.166											
		Bv'	0.176											
White		Wu'	0.198											
		Wv'	0.468											
C.G.L	White	$\Delta u'v'$	-	-	0.02		(9)							

* C.G.L : Color Grayscale Linearity

(continue to the next page)

Item	Symbol	Condition	Min.	Typ.	Max.	Unit	Note
Color Gamut	-		-	102	-	%	
Color Temperature	-		-	6500	-	K	
Viewing Angle	Hor.	θ_L	-	89	-	Degrees	(8) SR-3
		θ_R	-	89	-		
	Ver.	θ_U	-	89	-		
		θ_D	-	89	-		
Viewing Angle	Hor.	θ_L	-	75	-	Degrees	(8) SR-3
		θ_R	-	75	-		
	Ver.	θ_U	-	65	-		
		θ_D	-	65	-		
Brightness Uniformity (13 Points)	B_{uni}		-	-	25	%	(4) SR-3

Note (1) Test Equipment Setup

The measurement should be executed in a stable, windless and dark room between 30min after lighting the back light at the given temperature for stabilization of the back light. This should be measured in the center of screen.

Single lamp current : 6.0mA

Environment condition : $T_a = 25 \pm 2 \text{ }^\circ\text{C}$

Photo detector	Field
SR-3	1°
BM-7	2°

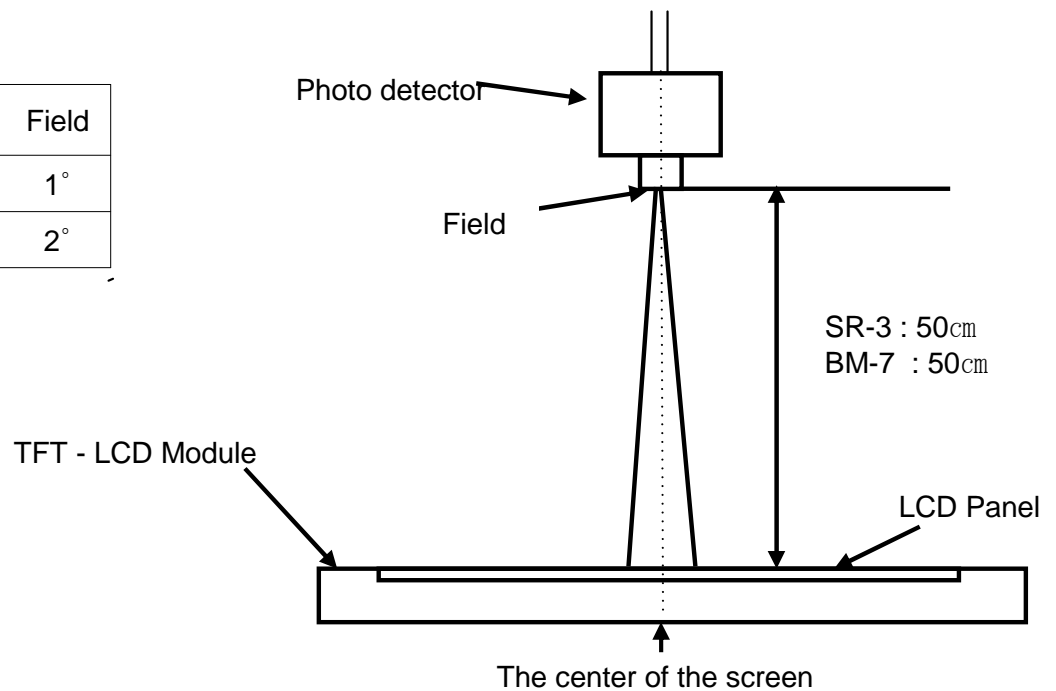

Note (2) Definition of test point

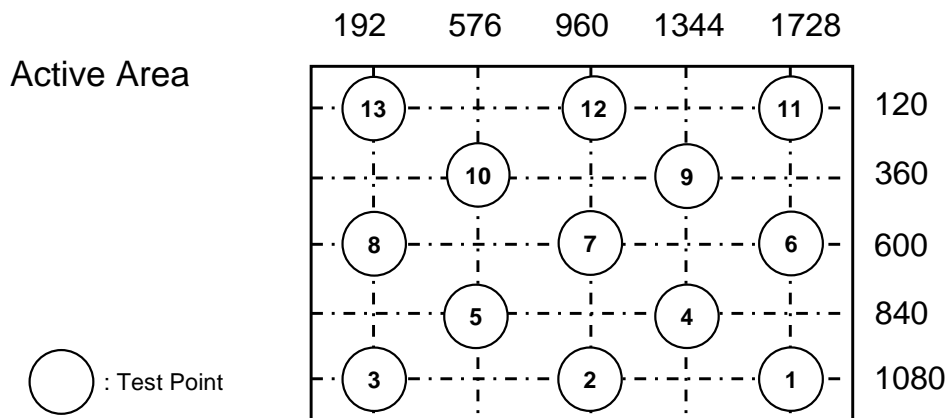

Note (3) Definition of Contrast Ratio (C/R)

: Ratio of gray max (Gmax) & gray min (Gmin) at the center point⑦ of the panel

$$CR = \frac{G \text{ max}}{G \text{ min}}$$

* If the Dynamic C/R operating is applied to 270M1-L01

Gmax : Luminance with all pixels white.

Gmin : Luminance with all pixels black.

Note (4) Definition of 13 points brightness uniformity (Full White pattern)

$$Buni = 100 \times \frac{(B \text{ max} - B \text{ min})}{B \text{ max}}$$

Bmax : Maximum brightness

Bmin : Minimum brightness

Note (5) Definition of Response time

a. On/Off response time : Sum of T_r , T_f

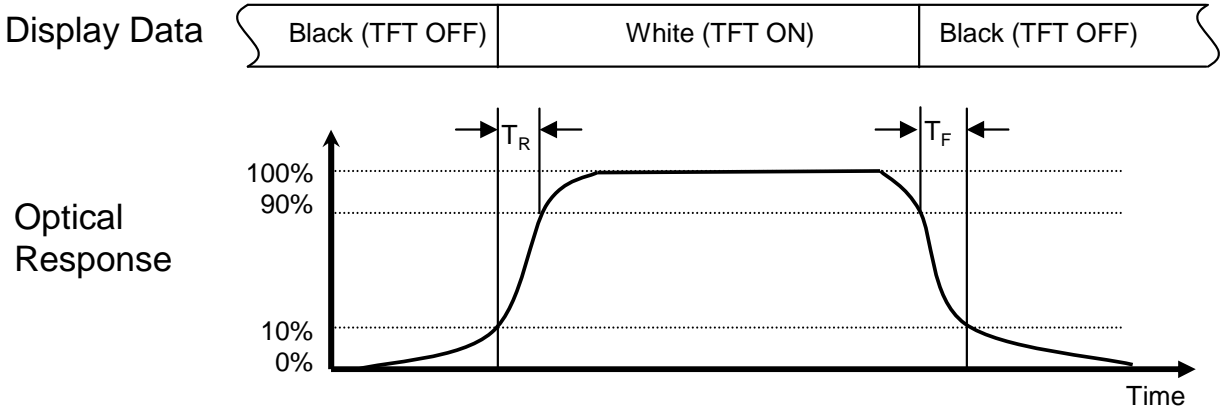

b. Gray to Gray Response Time

- Measuring gray : 31 → 63, 63 → 95, 95 → 127, 127 → 159, 159 → 191, 191 → 223 grays and vice versa
- $T_{G-G, avg}$: Average response time of ones between above grays

(Example)

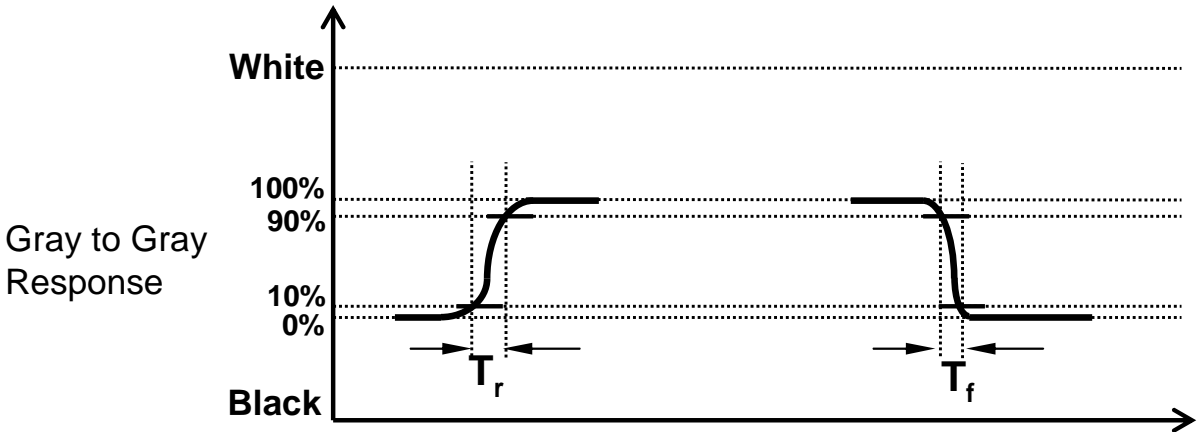

Note (6) Definition of Luminance of White : Luminance of white at center point⑤

Note (7) Definition of Color Chromaticity (CIE 1931, CIE1976)
Color coordinate of Red, Green, Blue & White at center point⑤

Note (8) Definition of Viewing Angle
: Viewing angle range ($CR \geq 10$, $CR \geq 100$)

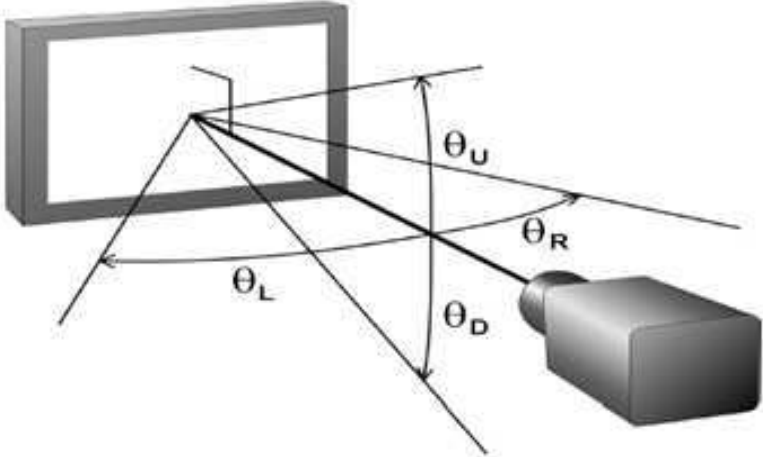

Note (9) Color Grayscale Linearity

- a. Test image : 100% full white pattern with a test pattern as below
- b. Test pattern : Squares, 40mm by 40mm in size, filled with 255, 225, 195, 165, 135 and 105 grays steps should be arranged at the center^⑤ of the screen.



c. Test method

- 1st gray step : move a square of 255 gray level should be moved into the center of the screen and measure luminance and u' and v' coordinates.
- Next gray step : Move a 225 gray square into the center and measure both luminance and coordinates, too.

d. Test evaluation

$$\Delta u'v' = \sqrt{(u'_A - u'_B)^2 + (v'_A - v'_B)^2}$$

Where A, B : 2 gray levels found to have the largest color differences between them
i.e. get the largest $\Delta u'$ and $\Delta v'$ of each 6 pair of u' and v' and calculate the $\Delta u'v'$.

3. Electrical Characteristics

3.1 TFT LCD Module

The connector for display data & timing signal should be connected. (GND=0V)

Ta = 25°C

Item		Symbol	Min.	Typ.	Max.	Unit	Note
Voltage of Power Supply		V_{DD}	4.5	5.0	5.5	V	(1)
LVDS Input Characteristics	Differential Input Voltage for LVDS Receiver Threshold	High	-	-	+100	mV	(2)
		Low	-100	-	-	mV	
	LVDS skew	t_{SKEW}	-300	-	300		(3)
	Differential input voltage	$ V_{ID} $	200	-	600	mV	(4)
	Input voltage range (single-ended)	V_{IN}	0	-	2.4	V	(4)
	Common mode voltage	V_{CM}	0+ $ V_{ID} /2$	1.2	2.4- $ V_{ID} /2$	V	(4)
	Input current	I_{IN}			± 10	μA	
Current of Power Supply	(a) Black	I_{DD}	-	1600	-	mA	(5),(6)
	(b) White		-	2200	-	mA	
	(c) Dot		-	2600	3000	mA	
Vsync Frequency		f_V	57	60	63	Hz	
Hsync Frequency		f_H	69	74	78.5	kHz	
Main Frequency		f_{DCLK}	72.0	77.0	81.0	MHz	
Rush Current		I_{RUSH}	-	-	4.5	A	(7)

Note (1) The ripple voltage should be controlled under 10% of V_{DD} .

- (2) Differential receiver voltage definitions and propagation delay and transition time test circuit
- a. All input pulses have frequency = 10MHz, t_R or $t_F=1ns$
 - b. C_L includes all probe and fixture capacitance

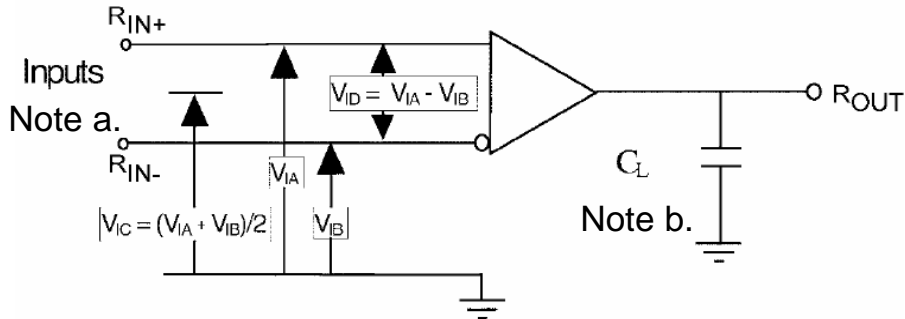

(3) LVDS Receiver DC parameters are measured under static and steady conditions which may not be reflective of its performance in the end application.

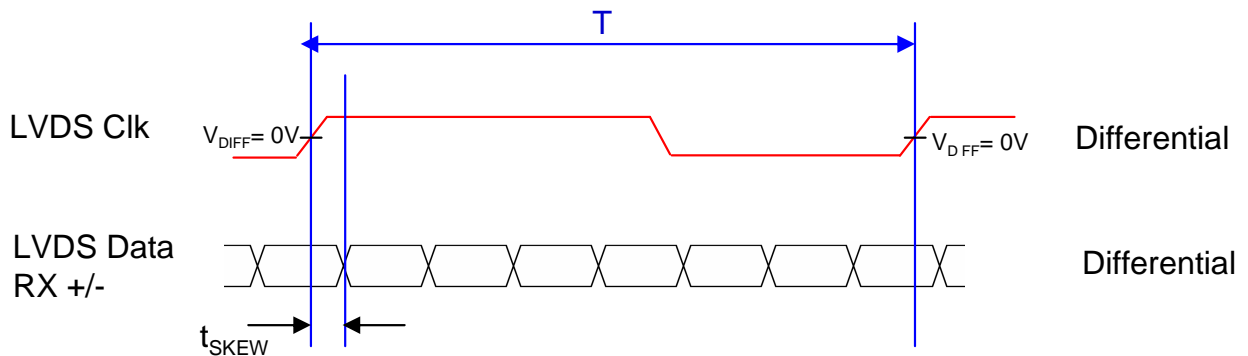

where t_{skew} : skew between LVDS clock & LVDS data,

T : 1 period time of LVDS clock

cf) (-/+) of 380psec means LVDS data goes before or after LVDS clock.

(4) Definition of V_{ID} and V_{CM} using single-end signals

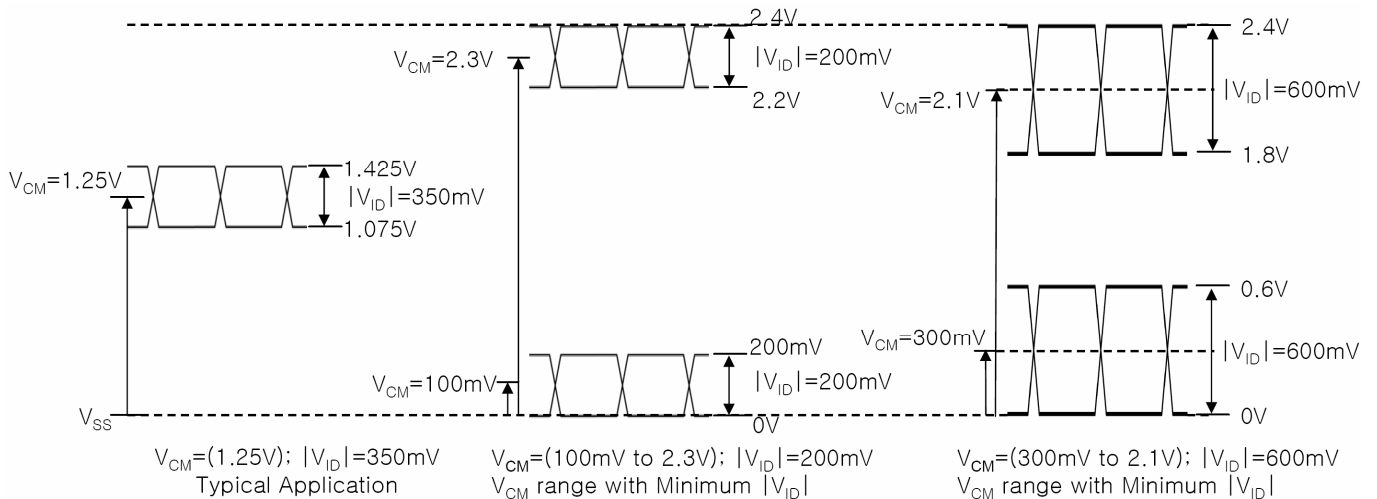

(5) $f_V=60\text{Hz}$, $f_{DCLK} = 77\text{MHz}$, $V_{DD} = 5.0\text{V}$, DC Current.

(6) Power dissipation check pattern (LCD Module only)

a) Black Pattern



b) White Pattern



c) Dot Pattern

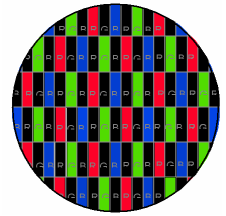
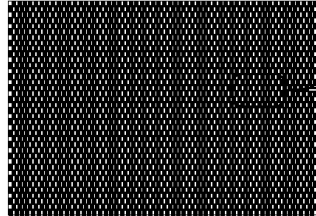

(7) Measurement Condition

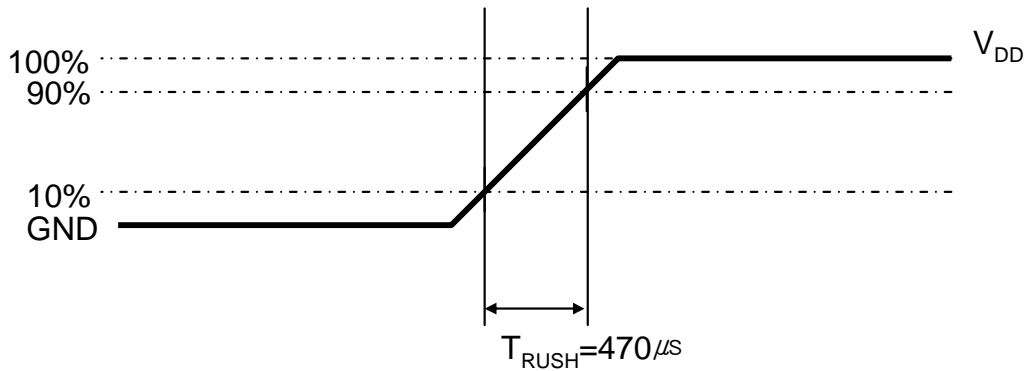

Rush Current I_{RUSH} can be measured when T_{RUSH} is $470\mu\text{s}$.

3.2 Back Light Unit

The back light unit is a direct type with 8 U-Type CCFLs (Cold Cathode Fluorescent Lamp)
The characteristics of a lamp is shown in the following table.

$T_a=25 \pm 2^\circ\text{C}$

Item	Symbol	Min.	Typ.	Max.	Unit	Note	
Lamp Current	I_L	5.0	6.0	7.0	mArms	(1)	
PWM Dimming Ratio		30		100	%	@6.0mA	
Lamp Voltage	V_L	-	1970	-	Vrms		
Lamp Frequency	f_L	40	-	60	kHz	(3)	
Operating Life Time	Hr	30,000	-	-	Hour	(4)	
Inverter waveform	Asymmetry rate	Wasy	-	-	10	%	(5)
	Distortion rate	Wdis	1.2726	1.414	1.5554		
Startup Voltage	V_s	-	-	0°C : 3180	Vrms	(6)	
				25°C : 2540			

Note (1) Specified values are for a single lamp.

Lamp current is measured with current meter for high frequency as shown below.
Refer to the following block diagram of the back light unit for more information.

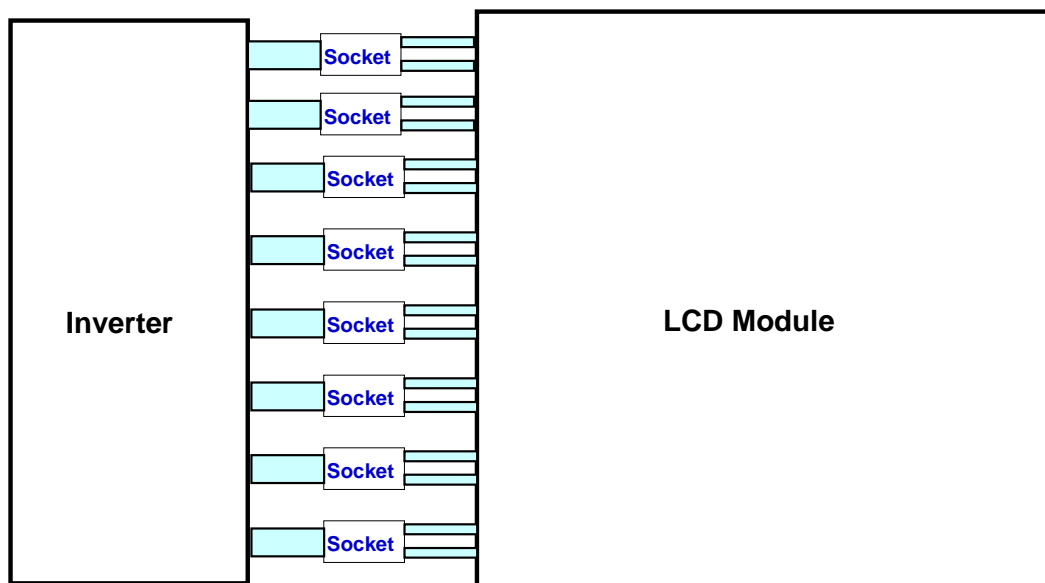

Fig. Measurement point of Lamp Current

(2) Define of Lamp current uniformity : I_{UNI}

$$I_{UNI} = \frac{|I_{Max} - I_{Min}|}{I_{Max}} \times 100$$

I_{max} : Maximum lamp current

I_{min} : Minimum lamp current

Lamp current uniformity I_{UNI} should be less than 25%

(3) Lamp frequency which may produce interference with horizontal synchronous frequency may cause line flow on the display. Therefore lamp frequency should be detached from the horizontal synchronous frequency and its harmonics as far as possible in order to avoid interference.

(4) Life time (Hr) is defined as the time when brightness of a lamp unit itself becomes 50% or less than its original value at the condition of $T_a = 25 \pm 2^\circ\text{C}$ and $I_L = 7.0\text{mA rms}$

(5) Designing a system inverter intended to have better display performance, power efficiency and lamp reliability.

They would help increase the lamp lifetime and reduce leakage current.

- The measurement should be done at typical lamp current.
- The asymmetry rate of the inverter waveform should be less than 10%.
- The distortion rate of the waveform should be $\sqrt{2}$ with $\pm 10\%$ tolerance.
 - Inverter output waveform had better be more similar to ideal sine wave.

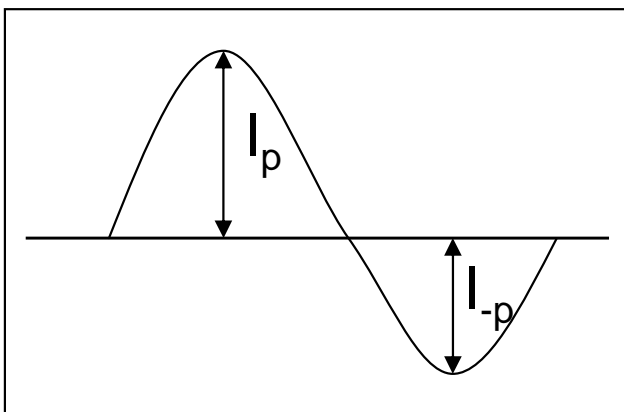

Fig. Wave form of the inverter

- Asymmetry rate

$$\frac{|I_p - I_{-p}|}{I_{rms}} \times 100$$

- Distortion rate

$$\left| \frac{I_p}{I_{rms}} \right| \text{ or } \left| \frac{I_{-p}}{I_{rms}} \right|$$

(6) If an inverter has shutdown function, it should keep its output for over 1 second even if the lamp connector is open. Otherwise the lamps may not be turned on.

4. BLOCK DIAGRAM

4.1 TFT LCD Module

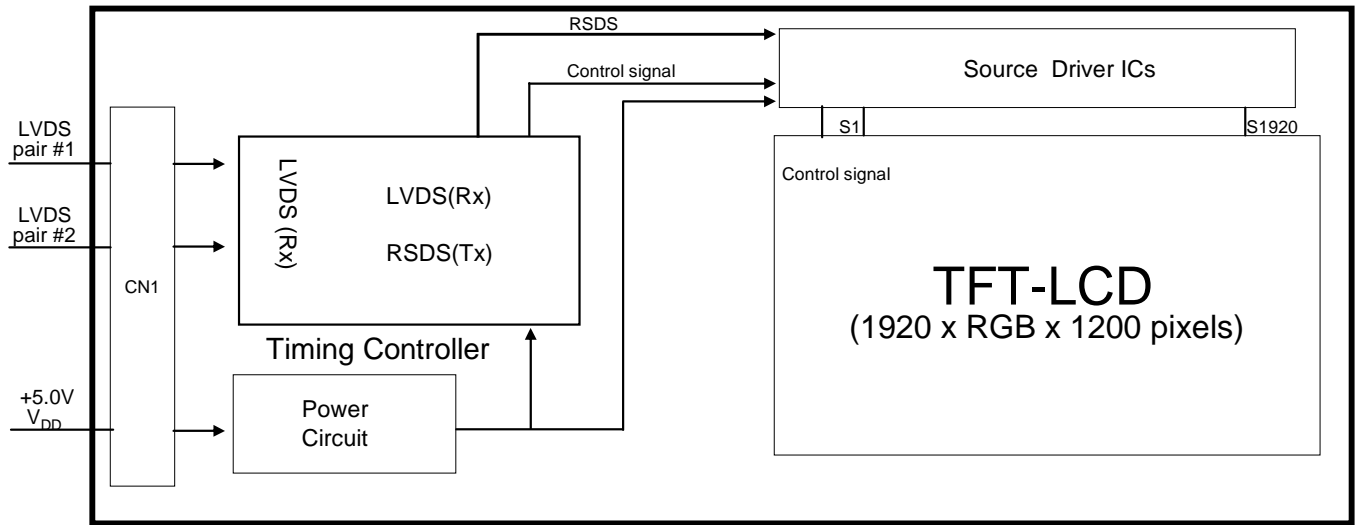

4.2 Back Light Unit

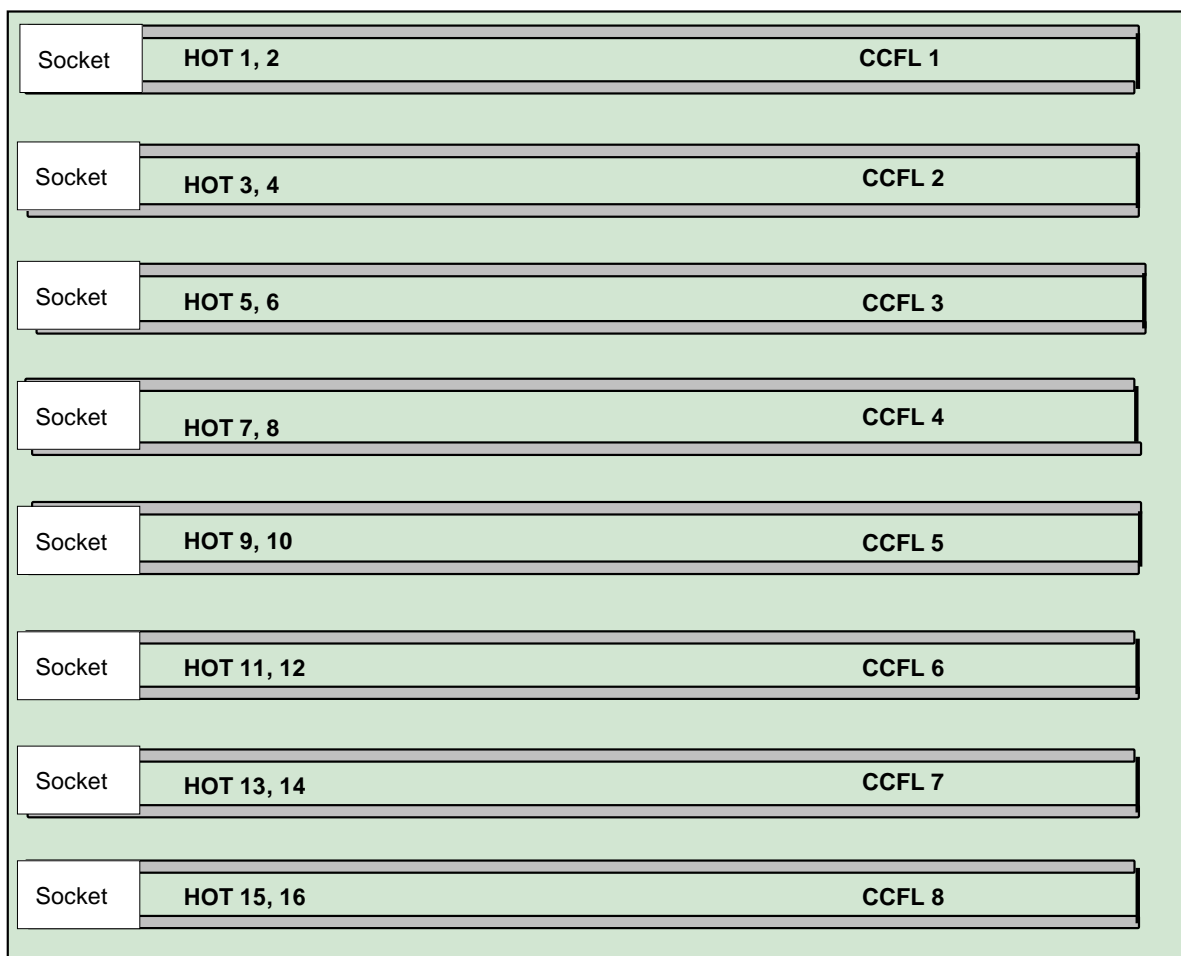

5. Input Terminal Pin Assignment

5.1.1 Input Signal & Power (Connector : UJU IP125-C41B-C42)

PIN NO	SYMBOL	FUNCTION
1	GND	Ground
2	RX00N	Negative LVDS differential data output
3	RX00P	Positive LVDS differential data output
4	RX01N	Negative LVDS differential data output
5	RX01P	Positive LVDS differential data output
6	RX02N	Negative LVDS differential data output
7	RX02P	Positive LVDS differential data output
8	RXOCN	Negative Sampling Clock (ODD data)
9	RXOCP	Positive Sampling Clock (ODD data)
10	RX03N	Negative LVDS differential data output
11	RX03P	Positive LVDS differential data output
12	RX04N	Negative LVDS differential data output
13	RX04P	Positive LVDS differential data output
14	GND	Ground
15	RXE0N	Negative LVDS differential data output
16	RXE0P	Positive LVDS differential data output
17	RXE1N	Negative LVDS differential data output
18	RXE1P	Positive LVDS differential data output
19	RXE2N	Negative LVDS differential data output
20	RXE2P	Positive LVDS differential data output
21	RXECN	Negative Sampling Clock (EVEN data)
22	RXECP	Positive Sampling Clock (EVEN data)
23	RXE3N	Negative LVDS differential data output
24	RXE3P	Positive LVDS differential data output
25	RXE4N	Negative LVDS differential data output
26	RXE4P	Positive LVDS differential data output
27	GND	Ground
28	GND	Ground
29	SIC Control	* Smart Inverter Control Disable. - High (3.3V) : SIC Disable - Low(0V) : SIC Enable ※ Do not float the pin.
30	DCC Control	- High (3.3V) : DCC Disable - Low(0V) : DCC Enable ※ Do not float the pin.
31	GND	Ground
32	NC	* CE (For LCD internal use only. Do not connect)
33	NC	* CTL (For LCD internal use only. Do not connect)
34	GND	Ground
35	VDD	Power Supply : +5V
36	VDD	
37	VDD	
38	VDD	
39	VDD	
40	VDD	
41	GND	Ground

* If the system already uses the 32,33pins, it should keep under GND level
The voltage applied to those pins should not exceed -200mV.

5.1.2. Inverter Input Connector : 20022WR-14(L)(Yeonho) or Compatible.

Pin	Symbol	Description	Notes
1	V _{BL}	Power Supply, +24V	
2	V _{BL}	Power Supply, +24V	
3	V _{BL}	Power Supply, +24V	
4	V _{BL}	Power Supply, +24V	
5	V _{BL}	Power Supply, +24V	
6	GND	Power Ground	
7	GND	Power Ground	
8	GND	Power Ground	
9	GND	Power Ground	
10	GND	Power Ground	
11	VS	No connection	
12	V _{ON}	BL On/Off Control signal	ON : 2.4V~5..25V OFF : 0.0~0.8V
13	V _{BR}	PWM Dimming Control Signal	Dimming Rage : 0~2.2V
14	Status	Lamp Operating Status	Normal =0~0.8V Abnormal=3.0~5.0V

Note) Pin number starts from Left side

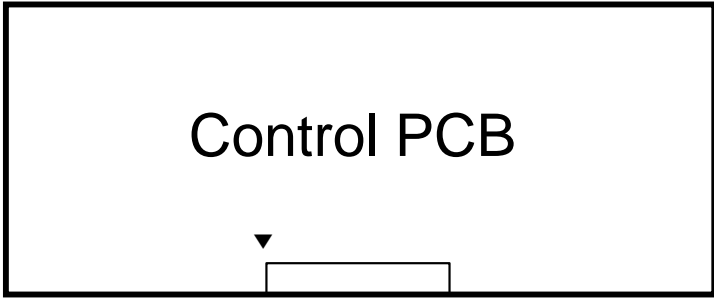

Pin No. 1 Pin No. 41

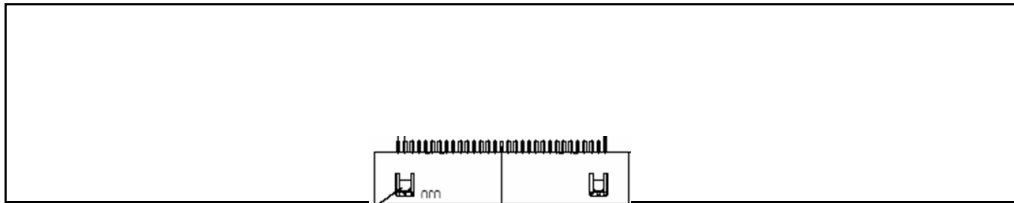

#1 #41



Fig. Connector diagram

- a. All GND pins should be connected together and also be connected to the LCD's metal chassis.
- b. All power input pins should be connected together.
- c. All NC pins should be separated from other signal or power.

5.2 Back Light Unit

Pin No.	Input	Function
1-1	HOT	High Voltage
1-2	HOT	High Voltage
2-1	HOT	High Voltage
2-2	HOT	High Voltage
3-1	HOT	High Voltage
3-2	HOT	High Voltage
4-1	HOT	High Voltage
4-2	HOT	High Voltage
5-1	HOT	High Voltage
5-2	HOT	High Voltage
6-1	HOT	High Voltage
6-2	HOT	High Voltage
7-1	HOT	High Voltage
7-2	HOT	High Voltage
8-1	HOT	High Voltage
8-2	HOT	High Voltage
Connector Part No.	Socket Type	

5.3 Input Signals, Basic Display Colors and Gray Scale of Each Color

COLOR	DISPLAY (10bit)	DATA SIGNAL																								GRAY SCALE LEVEL					
		RED									GREEN									BLUE											
		R0	R1	R2	R3	R4	R5	R6	R7	R8	R9	G0	G1	G2	G3	G4	G5	G6	G7	G8	G9	B0	B1	B2	B3		B4	B5	B6	B7	B8
BASIC COLOR	BLACK	0	0	0	0	0	0	0	0	0	0	0	0	0	0	0	0	0	0	0	0	0	0	0	0	0	0	0	0	-	
	BLUE	0	0	0	0	0	0	0	0	0	0	0	0	0	0	0	0	0	0	0	0	1	1	1	1	1	1	1	1	1	-
	GREEN	0	0	0	0	0	0	0	0	0	0	1	1	1	1	1	1	1	1	1	1	0	0	0	0	0	0	0	0	0	-
	CYAN	0	0	0	0	0	0	0	0	0	0	1	1	1	1	1	1	1	1	1	1	1	1	1	1	1	1	1	1	1	-
	RED	1	1	1	1	1	1	1	1	1	1	0	0	0	0	0	0	0	0	0	0	0	0	0	0	0	0	0	0	0	-
	MAGENTA	1	1	1	1	1	1	1	1	1	1	0	0	0	0	0	0	0	0	0	0	1	1	1	1	1	1	1	1	1	-
	YELLOW	1	1	1	1	1	1	1	1	1	1	1	1	1	1	1	1	1	1	1	1	0	0	0	0	0	0	0	0	0	-
	WHITE	1	1	1	1	1	1	1	1	1	1	1	1	1	1	1	1	1	1	1	1	1	1	1	1	1	1	1	1	1	-
GRAY SCALE OF RED	BLACK	0	0	0	0	0	0	0	0	0	0	0	0	0	0	0	0	0	0	0	0	0	0	0	0	0	0	0	0	R0	
	DARK ↑	1	0	0	0	0	0	0	0	0	0	0	0	0	0	0	0	0	0	0	0	0	0	0	0	0	0	0	0	R1	
		0	1	0	0	0	0	0	0	0	0	0	0	0	0	0	0	0	0	0	0	0	0	0	0	0	0	0	0	R2	
		:	:	:	:	:	:	:	:	:	:	:	:	:	:	:	:	:	:	:	:	:	:	:	:	:	:	:	:	:	R3~ R1020
		:	:	:	:	:	:	:	:	:	:	:	:	:	:	:	:	:	:	:	:	:	:	:	:	:	:	:	:	:	
	↓ LIGHT	1	0	1	1	1	1	1	1	1	1	0	0	0	0	0	0	0	0	0	0	0	0	0	0	0	0	0	0	R1021	
		0	1	1	1	1	1	1	1	1	1	0	0	0	0	0	0	0	0	0	0	0	0	0	0	0	0	0	0	R1022	
	RED	1	1	1	1	1	1	1	1	1	1	0	0	0	0	0	0	0	0	0	0	0	0	0	0	0	0	0	0	R1023	
GRAY SCALE OF GREEN	BLACK	0	0	0	0	0	0	0	0	0	0	0	0	0	0	0	0	0	0	0	0	0	0	0	0	0	0	0	0	G0	
	DARK ↑	0	0	0	0	0	0	0	0	0	0	1	0	0	0	0	0	0	0	0	0	0	0	0	0	0	0	0	0	G1	
		0	0	0	0	0	0	0	0	0	0	0	1	0	0	0	0	0	0	0	0	0	0	0	0	0	0	0	0	G2	
		:	:	:	:	:	:	:	:	:	:	:	:	:	:	:	:	:	:	:	:	:	:	:	:	:	:	:	:	G3~ G1020	
		:	:	:	:	:	:	:	:	:	:	:	:	:	:	:	:	:	:	:	:	:	:	:	:	:	:	:	:		
	↓ LIGHT	0	0	0	0	0	0	0	0	0	0	1	0	1	1	1	1	1	1	1	1	0	0	0	0	0	0	0	0	G1021	
		0	0	0	0	0	0	0	0	0	0	0	1	1	1	1	1	1	1	1	1	0	0	0	0	0	0	0	0	G1022	
	GREEN	0	0	0	0	0	0	0	0	0	0	1	1	1	1	1	1	1	1	1	1	0	0	0	0	0	0	0	0	G1023	
GRAY SCALE OF BLUE	BLACK	0	0	0	0	0	0	0	0	0	0	0	0	0	0	0	0	0	0	0	0	0	0	0	0	0	0	0	0	B0	
	DARK ↑	0	0	0	0	0	0	0	0	0	0	0	0	0	0	0	0	0	0	0	0	1	0	0	0	0	0	0	0	B1	
		0	0	0	0	0	0	0	0	0	0	0	0	0	0	0	0	0	0	0	0	0	1	0	0	0	0	0	0	B2	
		:	:	:	:	:	:	:	:	:	:	:	:	:	:	:	:	:	:	:	:	:	:	:	:	:	:	:	:	B3~ B1020	
		:	:	:	:	:	:	:	:	:	:	:	:	:	:	:	:	:	:	:	:	:	:	:	:	:	:	:	:		
	↓ LIGHT	0	0	0	0	0	0	0	0	0	0	0	0	0	0	0	0	0	0	0	0	1	0	1	1	1	1	1	1	B1021	
		0	0	0	0	0	0	0	0	0	0	0	0	0	0	0	0	0	0	0	0	0	1	1	1	1	1	1	1	B1022	
	BLUE	0	0	0	0	0	0	0	0	0	0	0	0	0	0	0	0	0	0	0	0	1	1	1	1	1	1	1	1	B1023	

Note (1) Definition of Gray :
 Rn : Red Gray, Gn : Green Gray, Bn : Blue Gray (n = Gray level)
 Input Signal : 0 = Low level voltage, 1 = High level voltage

6. Interface Timing

6.1 Timing Parameters (DE only mode)

SIGNAL	ITEM	SYMBOL	MIN.	TYP.	MAX.	Unit	NOTE
Clock	Frequency	$1/T_C$	72.0	77.0	81.0	MHz	-
Hsync		F_H	69	74	78.5	KHz	-
Vsync		F_V	57	60	63	Hz	-
Vertical Display Term	Active Display Period	T_{VD}	1200	1200	1200	lines	-
	Vertical Total	T_{VB}	1209	1235	1245	lines	-
Horizontal Display Term	Active Display Period	T_{HD}	960	960	960	clocks	-
	Horizontal Total	T_H	993	1040	1075	clocks	-

Note (1) This product is DE only mode. The input of Hsync & Vsync signal does not have an effect on normal operation.

(2) Test Point : TTL control signal and CLK at LVDS Tx input terminal in system

(3) Internal Vcc = 3.3V

(4) When operating the panel, DE signals have to the same period.

6.2 Timing diagrams of interface signal (DE only mode)

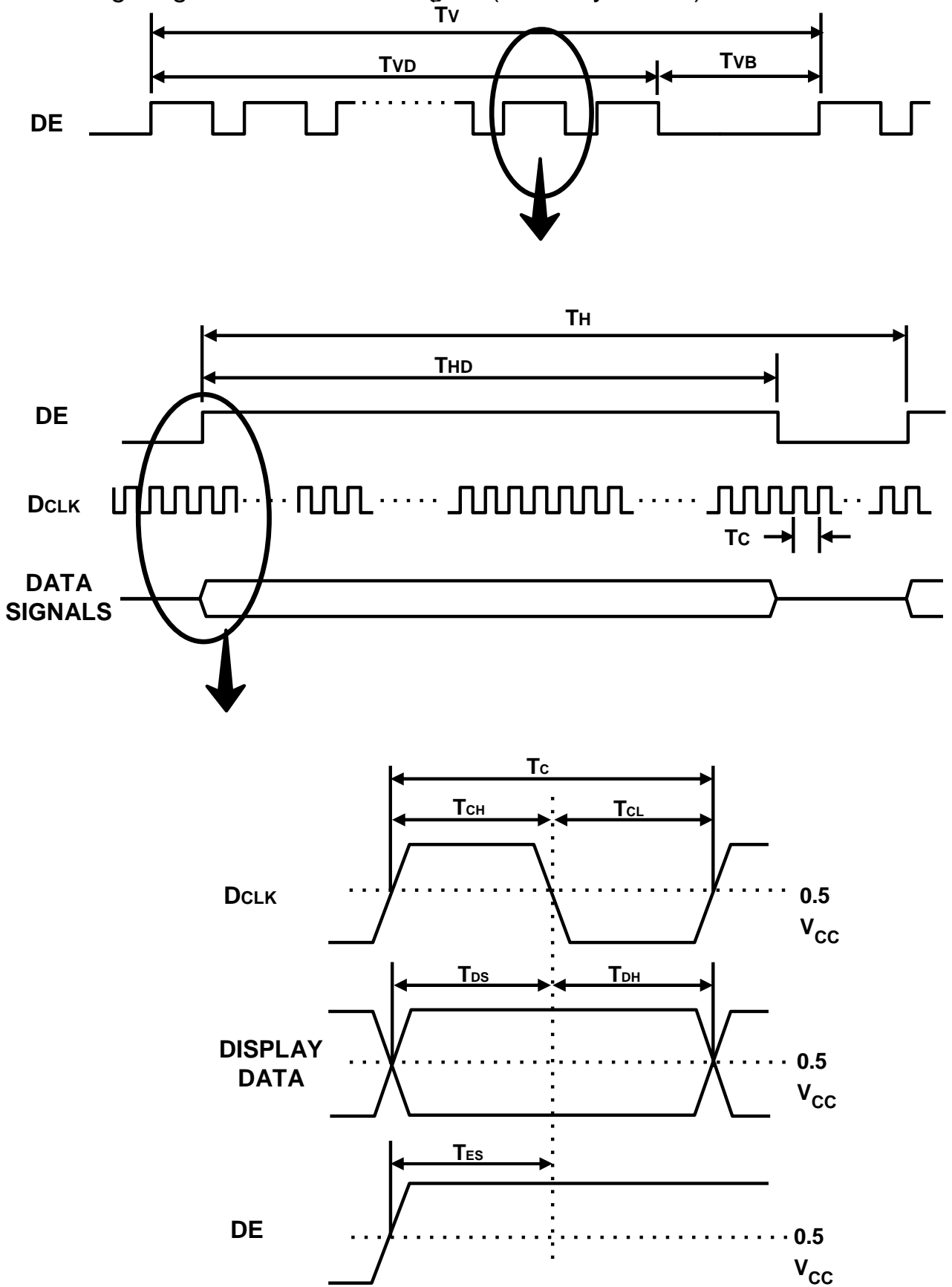

6.3 Power ON/OFF Sequence

To prevent a latch-up or DC operation of the LCD Module, the power on/off sequence should be as the diagram below.

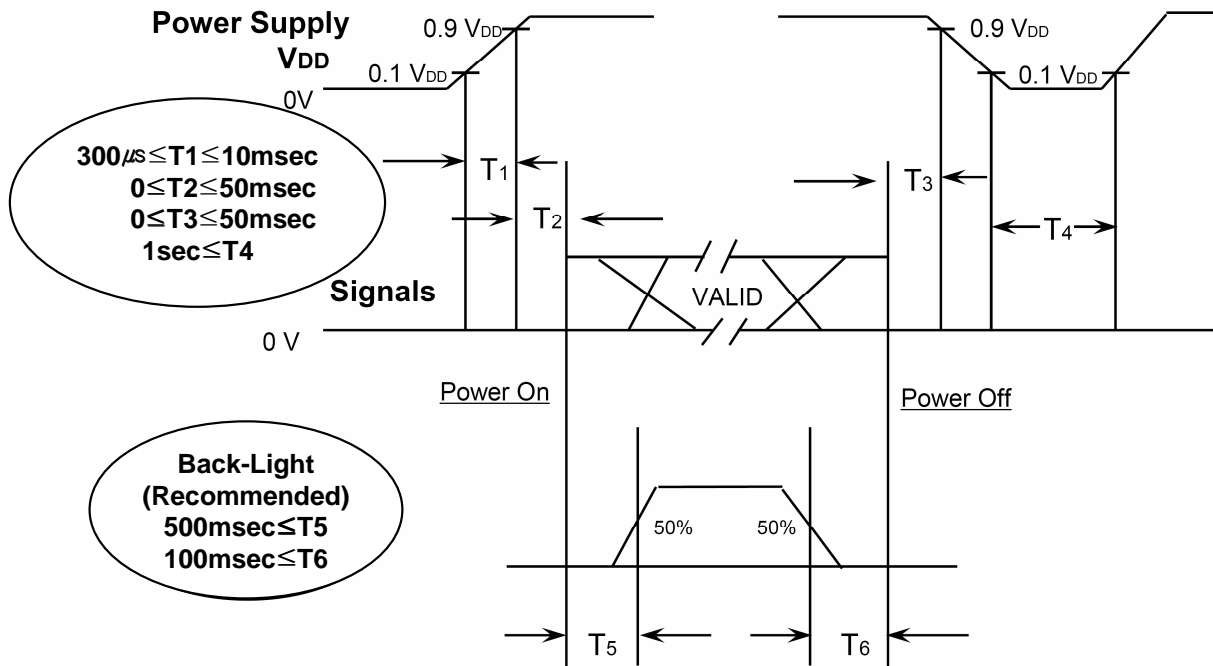

T1 : V_{DD} rising time from 10% to 90%

T2 : The time from V_{DD} to valid data at power ON.

T3 : The time from valid data off to V_{DD} off at power Off.

T4 : V_{DD} off time for Windows restart

T5 : The time from valid data to B/L enable at power ON.

T6 : The time from valid data off to B/L disable at power Off.

- The supply voltage of the external system for the Module input should be the same as the definition of V_{DD}.
- Apply the lamp voltage within the LCD operation range. When the back light turns on before the LCD operation or the LCD turns off before the back light turns off, the display may momentarily show abnormal screen.
- In case of V_{DD} = off level, please keep the level of input signals low or keep a high impedance.
- T4 should be measured after the Module has been fully discharged between power off and on period.
- Interface signal should not be kept at high impedance when the power is on.

6.4 Inverter Power Sequence

1) Rising Time of V_{IN}

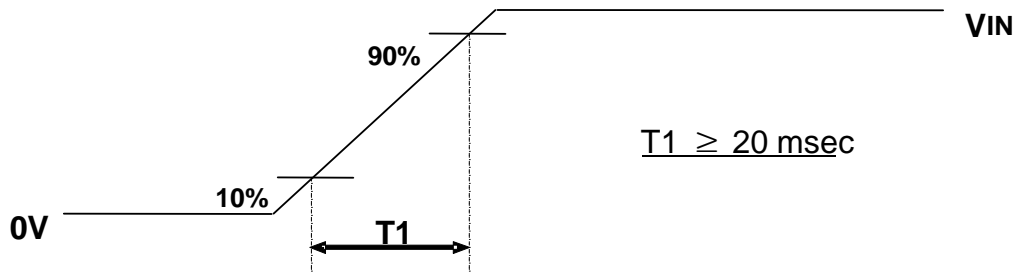

2) On/Off Sequence of V_{IN}

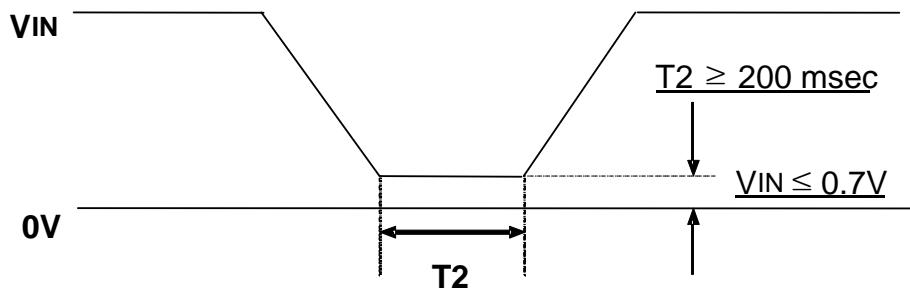

3) Power Sequence

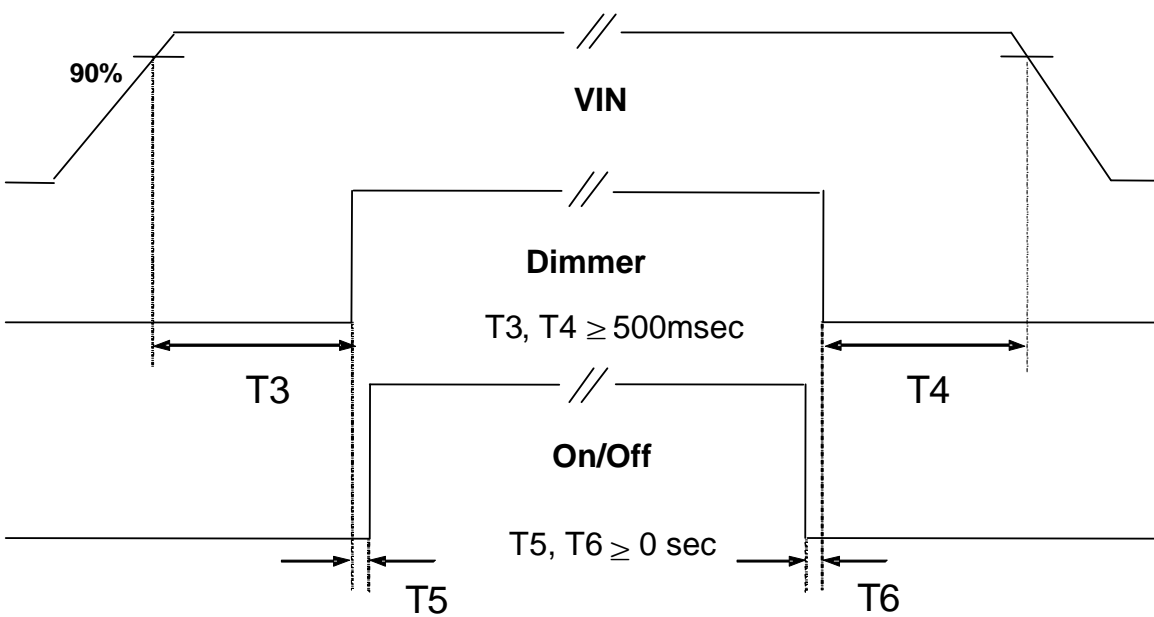

6.5 VDD Power Dip Condition

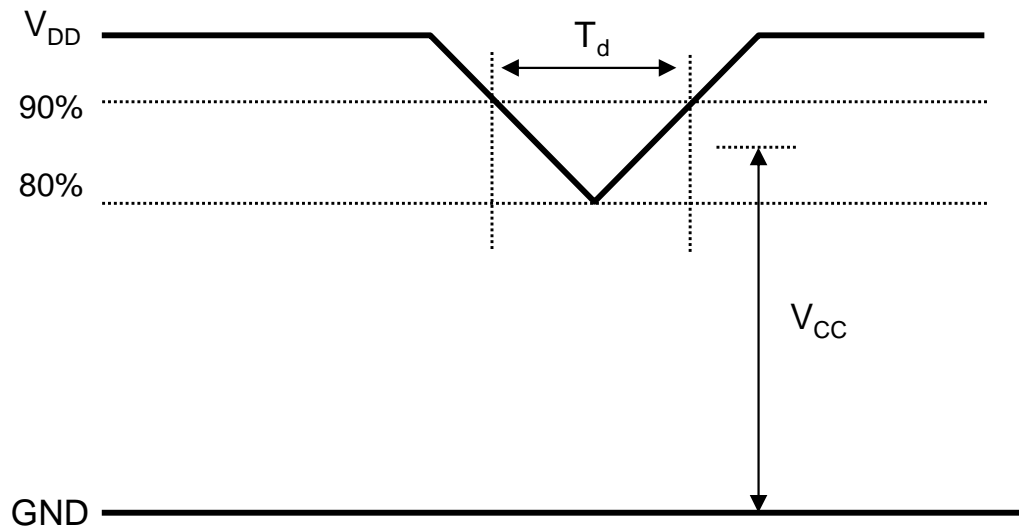

$$4.5V \leq V_{DD} \leq 5.5V$$

$$\text{If } V_{DD}(\text{typ.}) \times 80\% \leq V_{CC} \leq V_{DD}(\text{typ.}) \times 90\%$$

$$\text{Then, } 0 < T_d \leq 20\text{msec}$$

- Note (1) The above conditions are for the glitch of the input voltage.
 (2) For stable operation of an LCD Module power, please follow them.
 i.e., if $\text{typ } V_{DD} \times 80\% \leq V_{CC} \leq \text{typ } V_{DD} \times 90\%$, then T_d should be less than 20ms.

7. Outline Dimension

[Refer to the next pages.]

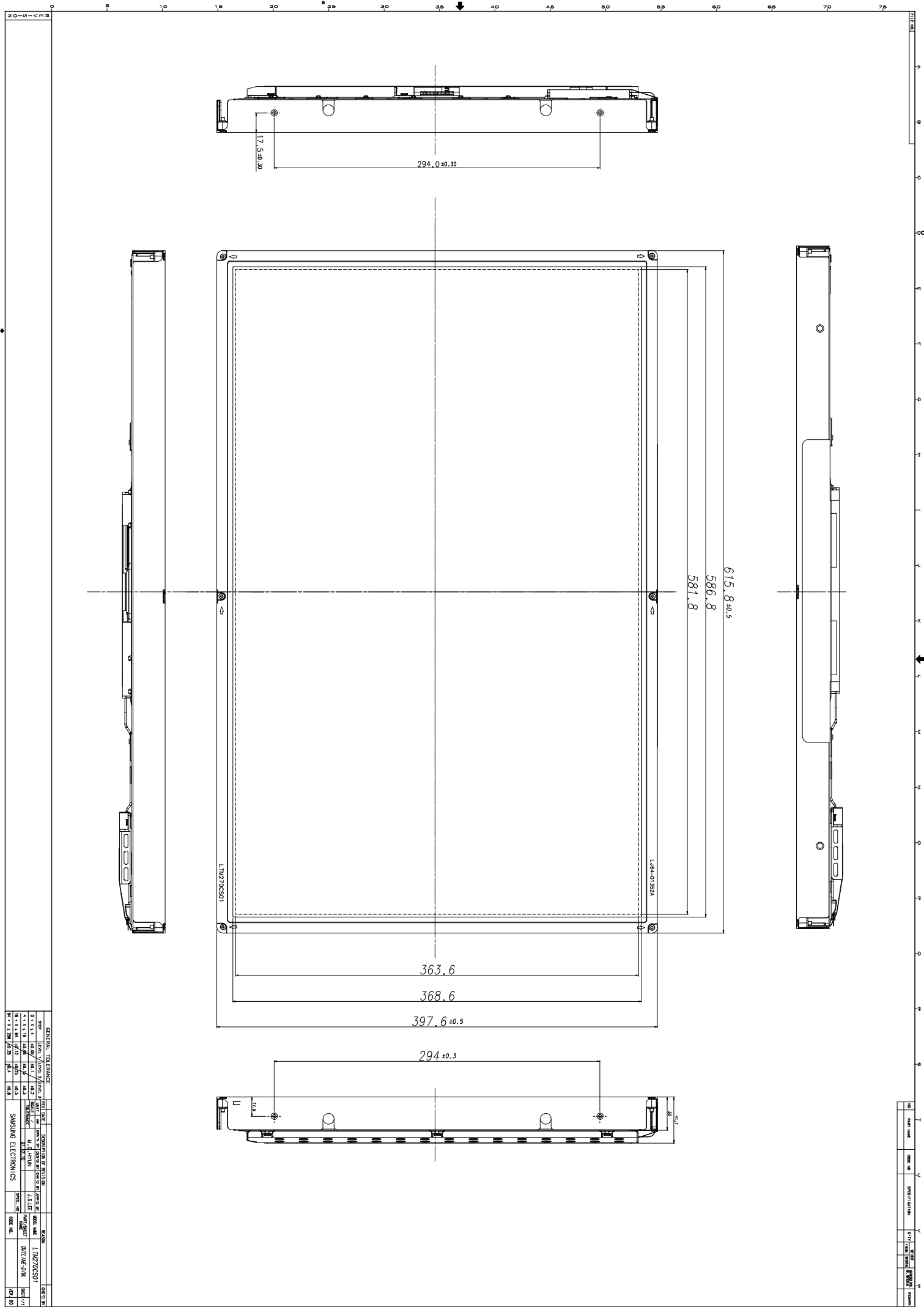

GENERAL TOLERANCE		DIMENSIONAL TOLERANCE		SURFACE FINISH		MATERIAL		DRAWING		REVISION	
±0.2	±0.1	±0.2	±0.1	±0.2	±0.1	±0.2	±0.1	±0.2	±0.1	±0.2	±0.1
±0.1	±0.05	±0.1	±0.05	±0.1	±0.05	±0.1	±0.05	±0.1	±0.05	±0.1	±0.05
±0.05	±0.02	±0.05	±0.02	±0.05	±0.02	±0.05	±0.02	±0.05	±0.02	±0.05	±0.02
±0.02	±0.01	±0.02	±0.01	±0.02	±0.01	±0.02	±0.01	±0.02	±0.01	±0.02	±0.01
±0.01	±0.005	±0.01	±0.005	±0.01	±0.005	±0.01	±0.005	±0.01	±0.005	±0.01	±0.005

NO.	DATE	BY	CHKD.	APP'D.	REVISION
01					

NO.	DATE	BY	CHKD.	APP'D.	REVISION
01					

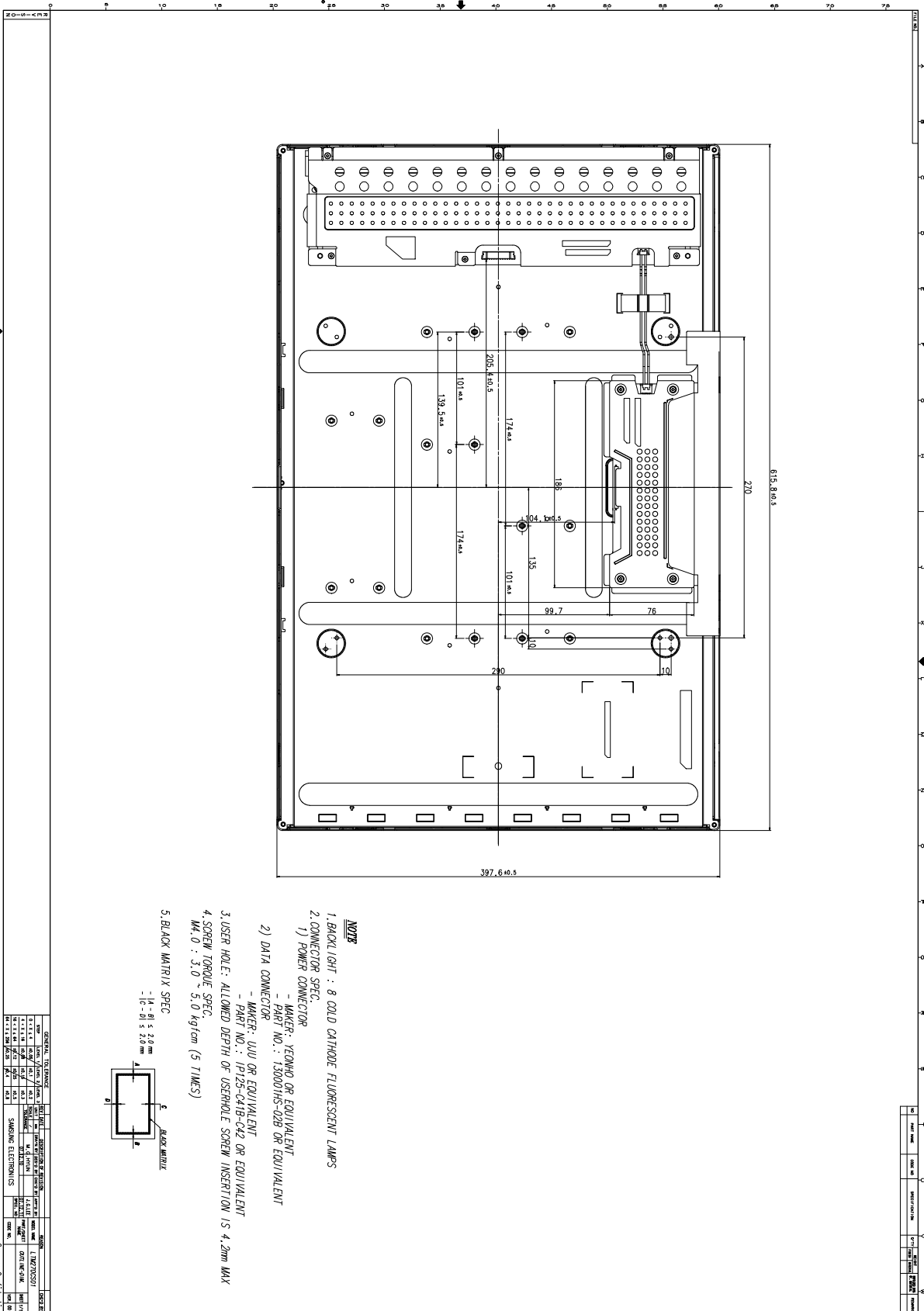

NOTES

1. BACKLIGHT : 8 COLD CATHODE FLUORESCENT LAMPS
2. CONNECTOR SPEC.
 - 1) POWER CONNECTOR
 - MAKER: YEONHO OR EQUIVALENT
 - PART NO.: 10007HS-02B OR EQUIVALENT
 - 2) DATA CONNECTOR
 - MAKER: UJU OR EQUIVALENT
 - PART NO.: 1P25-CA1B-CA2 OR EQUIVALENT
3. USER HOLE: ALLOWED DEPTH OF USERHOLE SCREW INSERTION IS 4.2mm MAX
4. SCREW TORQUE SPEC.
 - M4.0 : 3.0 ~ 5.0 kgfcm (5 TIMES)
5. BLACK MATRIX SPEC.
 - 14 - 21 x 2.0 mm

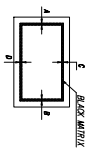

GENERAL INFORMATION		DESIGN INFORMATION		REVISION	
NO.	REV.	DATE	BY	NO.	REV.
1	1.1	10/27/05	YJ	1	1.1
2	1.2	11/10/05	YJ	2	1.2
3	1.3	11/10/05	YJ	3	1.3
4	1.4	11/10/05	YJ	4	1.4
5	1.5	11/10/05	YJ	5	1.5
6	1.6	11/10/05	YJ	6	1.6
7	1.7	11/10/05	YJ	7	1.7
8	1.8	11/10/05	YJ	8	1.8
9	1.9	11/10/05	YJ	9	1.9
10	2.0	11/10/05	YJ	10	2.0

Shanghai Cont'l (China) Ltd.

8. General Precautions

8.1 Handling

- (a) When the module is assembled, it should be attached to the system firmly using all mounting holes. Be careful not to twist and bend the module.
- (b) Because the inverter uses high voltages, it should be disconnected from power source before it is assembled or disassembled.
- (c) Refrain from strong mechanical shock and / or any force to the module. In addition to damage, it may cause improper operation or damage to the module and CCFT back light.
- (d) Note that polarizer films are very fragile and could be damaged easily. Do not press or scratch the surface harder than a HB pencil lead.
- (e) Wipe off water droplets or oil immediately. If you leave the droplets for a long time, staining or discoloration may occur.
- (f) If the surface of the polarizer is dirty, clean it using absorbent cotton or soft cloth.
- (g) Desirable cleaners are water, IPA (Isopropyl Alcohol) or Hexane. Do not use Ketone type materials (ex. Acetone), Ethyl alcohol, Toluene, Ethyl acid or Methyl chloride. It might cause permanent damage to the polarizer due to chemical reaction.
- (h) If the liquid crystal material leaks from the panel, it should be kept away from the eyes or mouth . In case of contact with hands, legs or clothes, it must be washed away with soap thoroughly.
- (i) Protect the Module from static, or the CMOS Gate Array IC would be damaged.
- (j) Use finger-stalls with soft gloves in order to keep display clean during the incoming inspection and assembly process.
- (k) Do not disassemble the Module.
- (l) Do not pull or fold the lamp wire.
- (m) Do not adjust the variable resistor located on the Module.
- (n) Protection film for polarizer on the Module should be slowly peeled off just before use so that the electrostatic charge can be minimized.
- (o) Pins of I/F connector should not be touched directly with bare hands.

8.2 Storage

- (a) Do not leave the Module in high temperature, and high humidity for a long time. It is highly recommended to store the Module with temperature from 0 to 35 °C and relative humidity of less than 70%.
- (b) Do not store the TFT-LCD Module in direct sunlight.
- (c) The Module should be stored in a dark place. It is prohibited to apply sunlight or fluorescent light in storing.

8.3 Operation

- (a) Do not connect or disconnect the Module in the "Power On" condition.
- (b) Power supply should always be turned on/off by the item 6.3 "Power on/off sequence"
- (c) Module has high frequency circuits. Sufficient suppression to the electromagnetic interference should be done by system manufacturers. Grounding and shielding methods may be important to minimize the interference.
- (d) The cable between the back light connector and its inverter power supply should be connected directly with a minimized length. A longer cable between the back light and the inverter may cause lower luminance of lamp (CCFT) and may require higher startup voltage (Vs).

8.4 Operation Condition Guide

- (a) The LCD product should be operated under normal conditions. Normal condition is defined as below;
 - Temperature : 20 ± 15 °C
 - Humidity : 65 ± 20 %
 - Display pattern : continually changing pattern (Not stationary)
- (b) If the product will be used in extreme conditions such as high temperature, humidity, display patterns or operation time etc., It is strongly recommended to contact SEC for Application engineering advice. Otherwise, its reliability and function may not be guaranteed. Extreme conditions are commonly found at Airports, Transit Stations, Banks, Stock market, and Controlling systems.

8.5 Others

- (a) Ultra-violet ray filter is necessary for outdoor operation.
- (b) Avoid condensation of water. It may result in improper operation or disconnection of electrode.
- (c) Do not exceed the absolute maximum rating value. (supply voltage variation, input voltage variation, variation in part contents and environmental temperature, and so on)
Otherwise the Module may be damaged.
- (d) If the Module keeps displaying the same pattern for a long period of time, the image may be "stuck" to the screen.
To avoid image sticking, it is recommended to use a screen saver.
- (e) This Module has its circuitry PCB's on the rear side and should be handled carefully in order not to be stressed.
- (f) Please contact SEC in advance when you display the same pattern for a long time.