

TFT LCD Approval Specification

MODEL NO.: M220Z1-L10

Customer : _____

Approved by : _____

Note :

記錄	工作	審核	角色	投票
2009-01-21 11:57:08 CST	PMMD II Director	kevin_wu(吳柏勳 /56520/54894)	Director	Accept

- CONTENTS -

REVISION HISTORY	3
1. GENERAL DESCRIPTION	4
1.1 OVERVIEW	
1.2 FEATURES	
1.3 APPLICATION	
1.4 GENERAL SPECIFICATIONS	
1.5 MECHANICAL SPECIFICATIONS	
2. ABSOLUTE MAXIMUM RATINGS	5
2.1 ABSOLUTE RATINGS OF ENVIRONMENT	
2.2 ELECTRICAL ABSOLUTE RATINGS	
2.2.1 TFT LCD MODULE	
2.2.2 BACKLIGHT UNIT	
3. ELECTRICAL CHARACTERISTICS	7
3.1 TFT LCD MODULE	
3.2 V _{CC} POWER DIP CONDITION	
3.3 BACKLIGHT UNIT	
4. BLOCK DIAGRAM	11
4.1 TFT LCD MODULE	
4.2 BACKLIGHT UNIT	
5. INPUT TERMINAL PIN ASSIGNMENT	12
5.1 TFT LCD MODULE	
5.2 LVDS DATA MAPPING TABLE	
5.3 BACKLIGHT UNIT	
5.4 COLOR DATA INPUT ASSIGNMENT	
6. INTERFACE TIMING	15
6.1 INPUT SIGNAL TIMING SPECIFICATIONS	
6.2 POWER ON/OFF SEQUENCE	
7. OPTICAL CHARACTERISTICS	17
7.1 TEST CONDITIONS	
7.2 OPTICAL SPECIFICATIONS	
8. PACKAGING	20
8.1 PACKING SPECIFICATIONS	
8.2 PACKING METHOD	
9. DEFINITION OF LABELS	22
9.1 CMO MODULE LABEL	
10. PRECAUTIONS	24
10.1 ASSEMBLY AND HANDLING PRECAUTIONS	
10.2 SAFETY PRECAUTIONS	
10.3 SAFETY STANDARDS	
10.4 OTHERS	
11. MECHANICAL CHARACTERISTICS	25



REVISION HISTORY

Version	Date	Section	Description
Ver 2.0	Jan,06 '09	All	M220Z1-L10 Specifications was first issued.

1. GENERAL DESCRIPTION

1.1 OVERVIEW

The M220Z1-L10 model is a 22 inch wide TFT-LCD module with a 2-CCFL Backlight Unit and a 30-pin 2ch-LVDS interface. This module supports 1680 x 1050 WSXGA⁺ (16:10 wide screen) mode and displays up to 16.7 millions colors. The inverter module for the Backlight Unit is not built in.

1.2 FEATURES

- Super wide viewing angle
- High contrast ratio
- Fast response time
- High color saturation (EBU Like Specifications)
- WSXGA⁺ (1680 x 1050 pixels) resolution
- DE (Data Enable) only mode
- LVDS (Low Voltage Differential Signaling) interface
- Lower power consumption
- HALEGEN Free

1.3 APPLICATION

- Workstation & desktop monitor
- Display terminals for AV application

1.4 GENERAL SPECIFICATIONS

Item	Specification	Unit	Note
Diagonal size	558.68	mm	
Active Area	473.76x296.1	mm	(1)
Bezel Opening Area	477.7 (H) x 300.1 (V)	mm	
Driver Element	a-Si TFT active matrix	-	-
Pixel Number	1680 x R.G.B. x 1050	pixel	-
Pixel Pitch	0.282(H) x 0.282(V)	mm	-
Pixel Arrangement	RGB vertical stripe	-	-
Display Colors	16.7 millions	color	-
Transmissive Mode	Normally White	-	-
Surface Treatment	Hard coating (3H), AG (Haze 25%)	-	-
Module Power Consumption	17.71	Watt	(2)

1.5 MECHANICAL SPECIFICATIONS

Item	Min.	Typ.	Max.	Unit	Note	
Module Size	Horizontal(H)	493.2	493.7	494.2	mm	(1)
	Vertical(V)	319.6	320.1	320.6	mm	
	Depth(D)	16	16.5	17	mm	
Weight			2920	g		
I/F connector mounting position	The mounting inclination of the connector makes the screen center within ± 0.5 mm as the horizontal.					

Note (1) Please refer to the attached drawings for more information of front and back outline dimensions.

Note (2) Please refer to sec.3.1 & 3.2 in this document for more information of power consumption.

2. ABSOLUTE MAXIMUM RATINGS

2.1 ABSOLUTE RATINGS OF ENVIRONMENT

Item	Symbol	Value		Unit	Note
		Min.	Max.		
Storage Temperature	T _{ST}	-20	+60	°C	(1)
Operating Ambient Temperature	T _{OP}	0	+50	°C	(1), (2)
Shock (Non-Operating)	S _{NOP}	-	50	G	(3), (5)
Vibration (Non-Operating)	V _{NOP}	-	1	G	(4), (5)
LCD Cell Life Time	L _{CELL}	50,000	-	Hrs	MTBF based

Note (1) Temperature and relative humidity range is shown in the figure below.

- (a) 90% RH Max. (Ta < 40 °C).
- (b) Wet-bulb temperature should be 39 °C Max. (Ta > 40 °C).
- (c) No condensation.

Note (2) The temperature of panel surface should be 0 °C Min. and 60 °C Max.

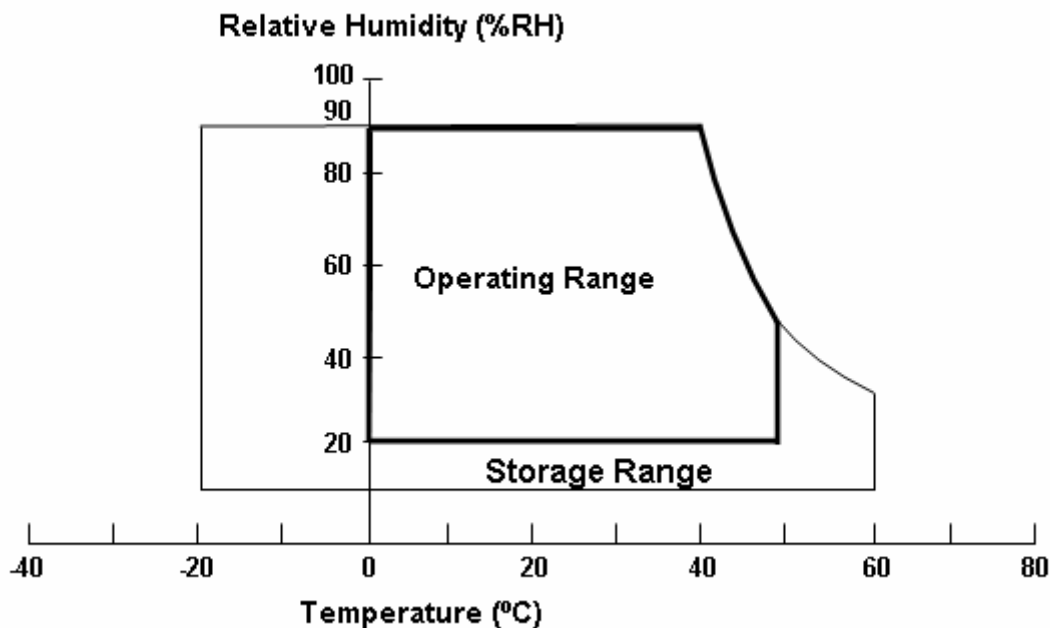

Note (3) 11 ms, half-sine wave, 1 time for ± X, ± Y, ± Z.

Note (4) 10 ~ 300 Hz, sweep rate 10 min / cycle , 30 min for X,Y,Z axis

Note (5) Upon the Vibration and Shock tests, the fixture used to hold the module must be firm and rigid enough to prevent the module from twisting or bending by the fixture.

2.2 ELECTRICAL ABSOLUTE RATINGS

2.2.1 TFT LCD MODULE

Item	Symbol	Value		Unit	Note
		Min.	Max.		
Power Supply Voltage	Vcc	-0.3	+5.5	V	(1)

2.2.2 BACKLIGHT UNIT

Item	Symbol	Value		Unit	Note
		Min.	Max.		
Lamp Voltage	V_L	-	2.5K	V_{RMS}	(1), (2), $I_L = 7.5 \text{ mA}$
Lamp Current	I_L	3.0	8.0	mA_{RMS}	(1), (2)
Lamp Frequency	F_L	40	80	KHZ	

Note (1) Permanent damage might occur if the module is operated at conditions exceeding the maximum values.

Note (2) Specified values are for lamp (Refer to 3.2 for further information).

3. ELECTRICAL CHARACTERISTICS

3.1 TFT LCD MODULE

Ta = 25 ± 2 °C

Parameter	Symbol	Value			Unit	Note
		Min.	Typ.	Max.		
Power Supply Voltage	V _{CC}	4.5	5.0	5.5	V	-
Ripple Voltage	V _{RP}	-	--	250	mV	-
Rush Current	I _{RUSH}	-	--	3	A	(2)
Power Supply Current	I _{CC}	White	630	819	mA	(3)a
		Black	1170	1521	mA	(3)b
		f _V = 75Hz, V _{CC} =4.5V	1330	1729	mA	(4)
Power Consumption	P _{LCD}	-	5.85	7.605	Watt	
LVDS differential input voltage	V _{id}	200	-	600	mV	
LVDS common input voltage	V _{ic}	--	1.2	--	V	

Above all conditions are VDD=5.0V, all black pattern at 75HZ.

Note (1) The module is recommended to operate within specification ranges listed above for normal function.

Note (2) Measurement Conditions:

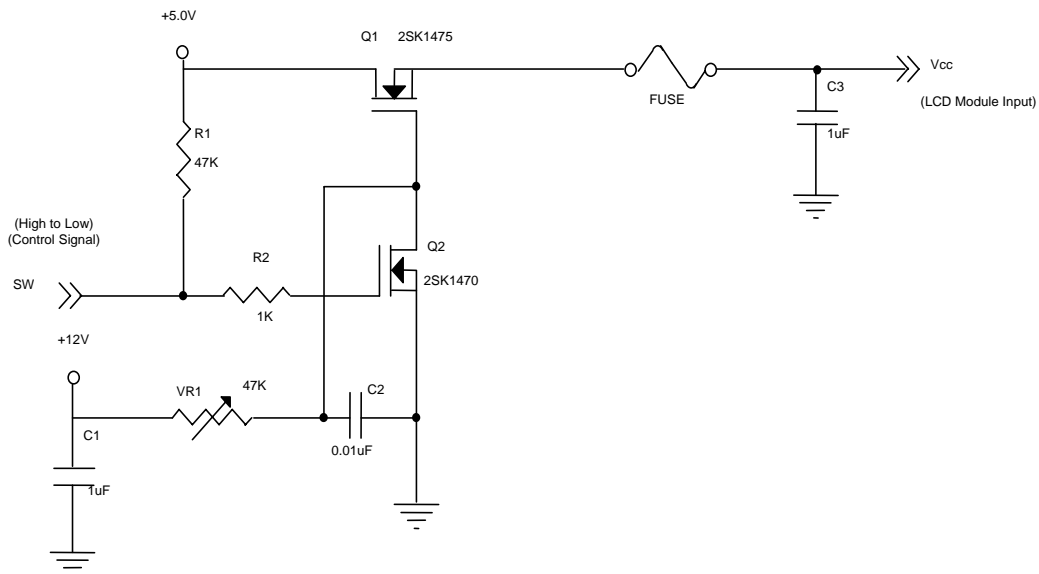

Vcc rising time is 470µs

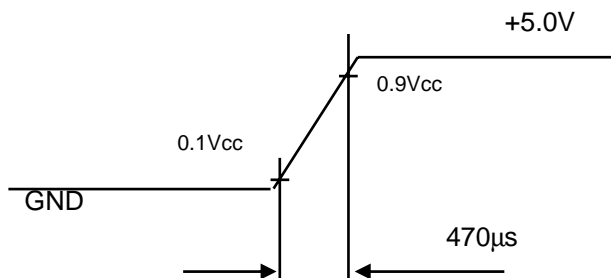

Note (3) The specified power supply current is under the conditions at $V_{cc} = 5.0\text{ V}$, $T_a = 25 \pm 2\text{ }^\circ\text{C}$, $f_v = 60\text{ Hz}$, whereas a power dissipation check pattern below is displayed.

a. White Pattern

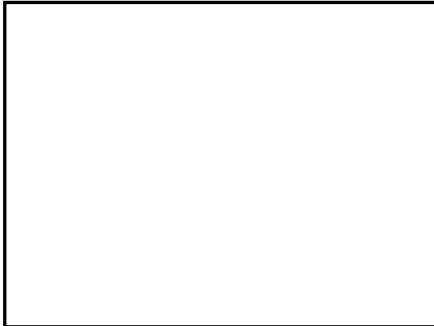

Active Area

b. Black Pattern



Active Area

Note (4) The specified power supply current is under the conditions at $V_{cc} = 4.5\text{ V}$, $T_a = 25 \pm 2\text{ }^\circ\text{C}$, $f_v = 75\text{ Hz}$, whereas a power dissipation check pattern (Black Pattern) below is displayed.

Black Pattern



Active Area

Note (5) The power consumption is specified at the pattern with the maximum current.

3.2 Vcc Power Dip Condition:

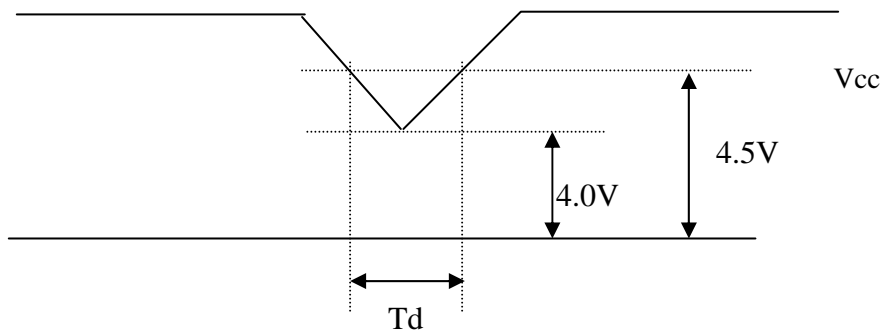

Dip condition: $4.0\text{V} \leq V_{cc} \leq 4.5\text{V}$, $T_d \leq 20\text{ms}$

3.2 BACKLIGHT UNIT

Parameter	Symbol	Value			Unit	Note
		Min.	Typ.	Max.		
Lamp Input Voltage	V_L	710	790	870	V_{RMS}	$I_L = 7.5 \text{ mA}$
Lamp Current	I_L	3	7.5	8	mA_{RMS}	(1)
Lamp Turn On Voltage	V_s	-	-	1560(25°C)	V_{RMS}	(2)
		-	-	1800(0°C)	V_{RMS}	(2)
Operating Frequency	F_L	40	60	80	KHz	(3)
Lamp Life Time	L_{BL}	50000		-	Hrs	(5) $I_L = 7.5 \text{ mA}$
Power Consumption	P_L	10.68	11.86	13.04	W	(4), $I_L = 7.5 \text{ mA}$

Note (1) Lamp current is measured by utilizing high-frequency current meters as shown below:

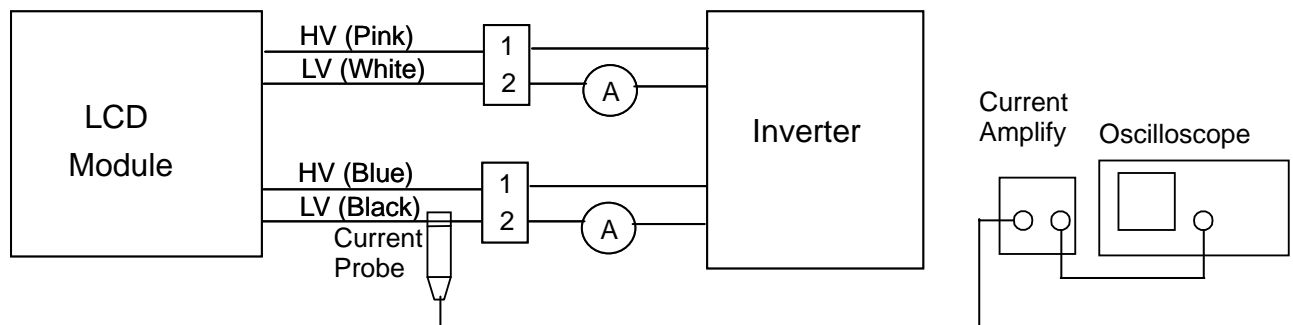

Measure equipment:
Current Amplify: Tektronix TCPA300
Current probe: Tektronix TCP312
Oscilloscope: TDS3054B

$$T_a = 25 \pm 2 \text{ }^\circ\text{C}$$

Note (2) The voltage that must be larger than V_s should be applied to the lamp for more than 1 second after startup. Otherwise, the lamp may not be turned on normally. It is the value output voltage of NF circuit.

Note (3) The lamp frequency may produce interference with horizontal synchronization frequency from the display, which might cause line flow on the display. In order to avoid interference, the lamp frequency should be detached from the horizontal synchronization frequency and its harmonics as far as possible.

Note (4) $P_L = I_L \times V_L \times 2\text{CCFLs}$

Note (5) The lifetime of lamp can be defined as the time in which it continues to operate under the condition $T_a = 25 \pm 2 \text{ }^\circ\text{C}$ and $I_L = 7.5 \text{ mA}_{RMS}$ until one of the following events occurs:

- (a) When the brightness becomes 50% of its original value.
- (b) When the effective ignition length becomes 80% of its original value.

(The effective ignition length is a scope that luminance is over 80% of that at the center point.)

Note (6) The waveform of the voltage output of inverter must be area-symmetric and the design of the inverter must have specifications for the modularized lamp. The performance of the Backlight, such as lifetime or brightness, is greatly influenced by the characteristics of the DC-AC inverter for the lamp. All the parameters of an inverter should be carefully designed to avoid producing too much current leakage from high voltage output of the inverter. When designing or ordering the

inverter please make sure that a poor lighting caused by the mismatch of the Backlight and the inverter (miss-lighting, flicker, etc.) never occurs. If the above situation is confirmed, the module should be operated in the same manners when it is installed in your instrument.

The output of the inverter must have symmetrical (negative and positive) voltage waveform and symmetrical current waveform. (Unsymmetrical ratio is less than 10%) Please do not use the inverter which has unsymmetrical voltage and unsymmetrical current and spike wave. Lamp frequency may produce interface with horizontal synchronous frequency and as a result this may cause beat on the display. Therefore lamp frequency shall be as away possible from the horizontal synchronous frequency and from its harmonics in order to prevent interference.

Requirements for a system inverter design, which is intended to have a better display performance, a better power efficiency and a more reliable lamp. It shall help increase the lamp lifetime and reduce its leakage current.

- a. The asymmetry rate of the inverter waveform should be 10% below;
- b. The distortion rate of the waveform should be within $2 \pm 10\%$;
- c. The ideal sine wave form shall be symmetric in positive and negative polarities.

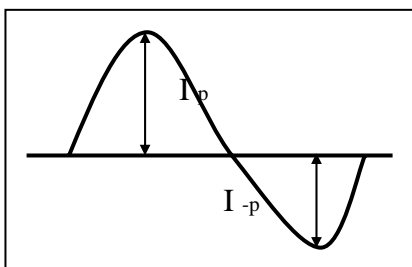

* Asymmetry rate:

$$\frac{|I_p - I_{-p}|}{I_{rms}} * 100\%$$

* Distortion rate

$$I_p \text{ (or } I_{-p}) / I_{rms}$$

4. BLOCK DIAGRAM

4.1 TFT LCD MODULE

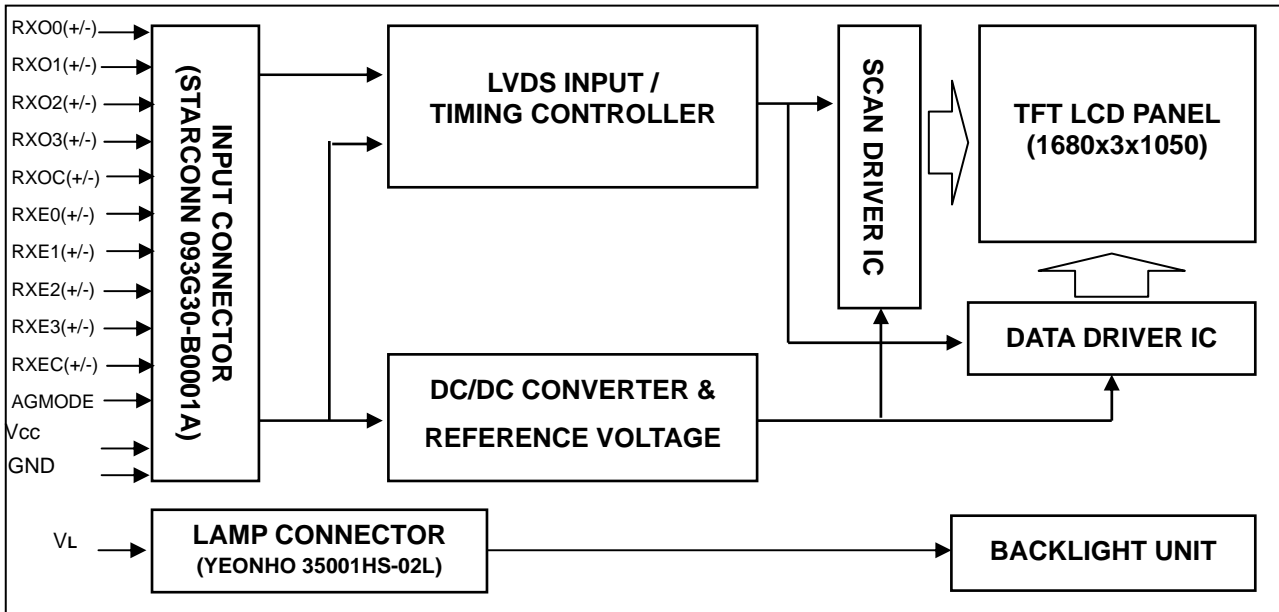

4.2 BACKLIGHT UNIT

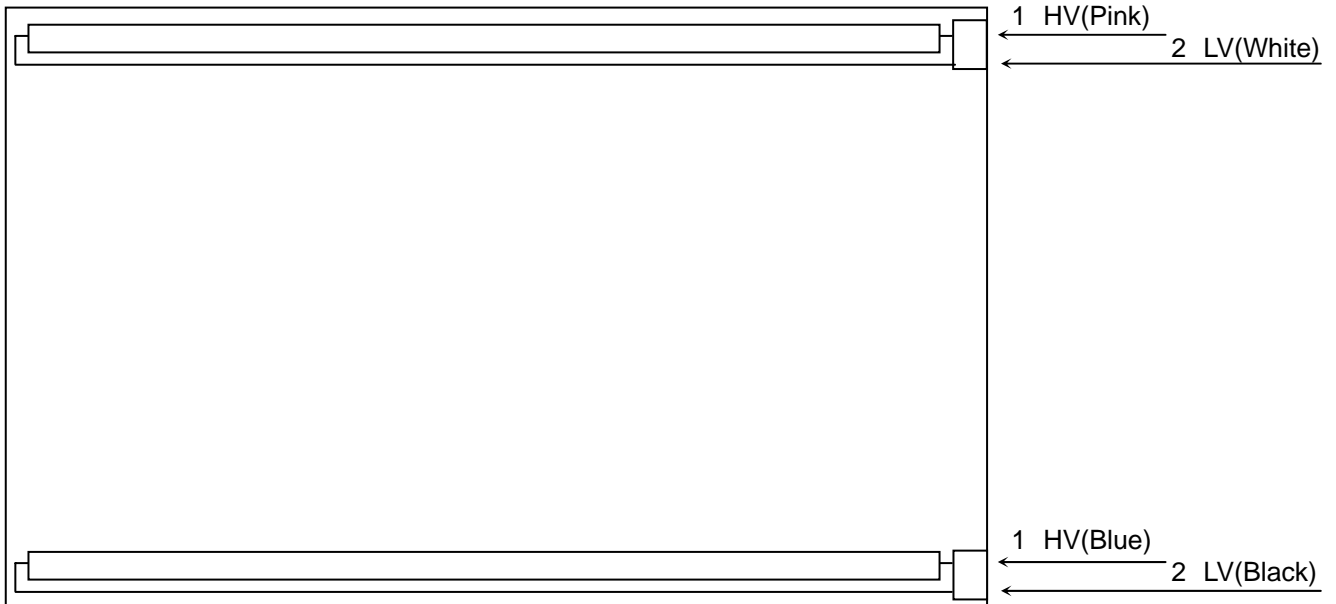

5. INPUT TERMINAL PIN ASSIGNMENT

5.1 TFT LCD MODULE

Pin	Name	Description
1	RXO0-	Negative LVDS differential data input. Channel O0 (odd)
2	RXO0+	Positive LVDS differential data input. Channel O0 (odd)
3	RXO1-	Negative LVDS differential data input. Channel O1 (odd)
4	RXO1+	Positive LVDS differential data input. Channel O1 (odd)
5	RXO2-	Negative LVDS differential data input. Channel O2 (odd)
6	RXO2+	Positive LVDS differential data input. Channel O2 (odd)
7	GND	Ground
8	RXOC-	Negative LVDS differential clock input. (odd)
9	RXOC+	Positive LVDS differential clock input. (odd)
10	RXO3-	Negative LVDS differential data input. Channel O3(odd)
11	RXO3+	Positive LVDS differential data input. Channel O3 (odd)
12	RXE0-	Negative LVDS differential data input. Channel E0 (even)
13	RXE0+	Positive LVDS differential data input. Channel E0 (even)
14	GND	Ground
15	RXE1-	Negative LVDS differential data input. Channel E1 (even)
16	RXE1+	Positive LVDS differential data input. Channel E1 (even)
17	GND	Ground
18	RXE2-	Negative LVDS differential data input. Channel E2 (even)
19	RXE2+	Positive LVDS differential data input. Channel E2 (even)
20	RXEC-	Negative LVDS differential clock input. (even)
21	RXEC+	Positive LVDS differential clock input. (even)
22	RXE3-	Negative LVDS differential data input. Channel E3 (even)
23	RXE3+	Positive LVDS differential data input. Channel E3 (even)
24	GND	Ground
25	NC	Not connection, should open.
26	VCOM	VCOM Control, should open.
27	AGMODE	AGMODE should be tied to ground or open.
28	VCC	+5.0V power supply
29	VCC	+5.0V power supply
30	VCC	+5.0V power supply

Note (1) Connector Part No.: 093G30-B0001A(STARCONN) or MSAKT2407P30HA (STM).

Note (2) Mating Connector Part No.:FI-X30H ; FI-X30C* ; FI-X30M* ; FI-X30HL(-T),FI-X30C*L(-T) [JAE]

Note (3) The first pixel is odd.

Note (4) Input signal of even and odd clock should be the same timing.

5.2 LVDS DATA MAPPING TABLE

LVDS Channel E0	LVDS output	D7	D6	D4	D3	D2	D1	D0
	Data order	EG0	ER5	ER4	ER3	ER2	ER1	ER0
LVDS Channel E1	LVDS output	D18	D15	D14	D13	D12	D9	D8
	Data order	EB1	EB0	EG5	EG4	EG3	EG2	EG1
LVDS Channel E2	LVDS output	D26	D25	D24	D22	D21	D20	D19
	Data order	DE	NA	NA	EB5	EB4	EB3	EB2
LVDS Channel E3	LVDS output	D23	D17	D16	D11	D10	D5	D27
	Data order	NA	EB7	EB6	EG7	EG6	ER7	ER6
LVDS Channel O0	LVDS output	D7	D6	D4	D3	D2	D1	D0
	Data order	OG0	OR5	OR4	OR3	OR2	OR1	OR0
LVDS Channel O1	LVDS output	D18	D15	D14	D13	D12	D9	D8
	Data order	OB1	OB0	OG5	OG4	OG3	OG2	OG1
LVDS Channel O2	LVDS output	D26	D25	D24	D22	D21	D20	D19
	Data order	DE	NA	NA	OB5	OB4	OB3	OB2
LVDS Channel O3	LVDS output	D23	D17	D16	D11	D10	D5	D27
	Data order	NA	OB7	OB6	OG7	OG6	OR7	OR6

5.3 BACKLIGHT UNIT

Pin	Symbol	Description	Remark
1	HV	High Voltage	Pink
2	LV	Low Voltage	White
1	HV	High Voltage	Blue
2	LV	Low Voltage	Black

Note (1) Connector Part No.: YEONHO 35001HS-02L or equivalent

Note (2) User's connector Part No.: YEONHO 35001WR-02L or equivalent

5.4 COLOR DATA INPUT ASSIGNMENT

The brightness of each primary color (red, green and blue) is based on the 8-bit gray scale data input for the color. The higher the binary input, the brighter the color. The table below provides the assignment of color versus data input.

Color		Data Signal																							
		Red								Green								Blue							
		R7	R6	R5	R4	R3	R2	R1	R0	G7	G6	G5	G4	G3	G2	G1	G0	B7	B6	B5	B4	B3	B2	B1	B0
Basic Colors	Black	0	0	0	0	0	0	0	0	0	0	0	0	0	0	0	0	0	0	0	0	0	0	0	0
	Red	1	1	1	1	1	1	1	1	0	0	0	0	0	0	0	0	0	0	0	0	0	0	0	0
	Green	0	0	0	0	0	0	0	0	1	1	1	1	1	1	1	1	0	0	0	0	0	0	0	0
	Blue	0	0	0	0	0	0	0	0	0	0	0	0	0	0	0	0	1	1	1	1	1	1	1	1
	Cyan	0	0	0	0	0	0	0	0	1	1	1	1	1	1	1	1	1	1	1	1	1	1	1	1
	Magenta	1	1	1	1	1	1	1	1	0	0	0	0	0	0	0	0	1	1	1	1	1	1	1	1
	Yellow	1	1	1	1	1	1	1	1	1	1	1	1	1	1	1	1	0	0	0	0	0	0	0	0
	White	1	1	1	1	1	1	1	1	1	1	1	1	1	1	1	1	1	1	1	1	1	1	1	1
Gray Scale Of Red	Red(0) / Dark	0	0	0	0	0	0	0	0	0	0	0	0	0	0	0	0	0	0	0	0	0	0	0	
	Red(1)	0	0	0	0	0	0	0	1	0	0	0	0	0	0	0	0	0	0	0	0	0	0	0	
	Red(2)	0	0	0	0	0	0	1	0	0	0	0	0	0	0	0	0	0	0	0	0	0	0	0	
	:	:	:	:	:	:	:	:	:	:	:	:	:	:	:	:	:	:	:	:	:	:	:	:	
	:	:	:	:	:	:	:	:	:	:	:	:	:	:	:	:	:	:	:	:	:	:	:	:	
	Red(253)	1	1	1	1	1	1	0	1	0	0	0	0	0	0	0	0	0	0	0	0	0	0	0	
	Red(254)	1	1	1	1	1	1	1	0	0	0	0	0	0	0	0	0	0	0	0	0	0	0	0	
Red(255)	1	1	1	1	1	1	1	1	0	0	0	0	0	0	0	0	0	0	0	0	0	0	0		
Gray Scale Of Green	Green(0) / Dark	0	0	0	0	0	0	0	0	0	0	0	0	0	0	0	0	0	0	0	0	0	0	0	
	Green(1)	0	0	0	0	0	0	0	0	0	0	0	0	0	0	1	0	0	0	0	0	0	0	0	
	Green(2)	0	0	0	0	0	0	0	0	0	0	0	0	0	0	1	0	0	0	0	0	0	0	0	
	:	:	:	:	:	:	:	:	:	:	:	:	:	:	:	:	:	:	:	:	:	:	:	:	
	:	:	:	:	:	:	:	:	:	:	:	:	:	:	:	:	:	:	:	:	:	:	:	:	
	Green(253)	0	0	0	0	0	0	0	0	1	1	1	1	1	1	0	1	0	0	0	0	0	0	0	
	Green(254)	0	0	0	0	0	0	0	0	1	1	1	1	1	1	0	0	0	0	0	0	0	0	0	
Green(255)	0	0	0	0	0	0	0	0	1	1	1	1	1	1	1	0	0	0	0	0	0	0	0		
Gray Scale Of Blue	Blue(0) / Dark	0	0	0	0	0	0	0	0	0	0	0	0	0	0	0	0	0	0	0	0	0	0	0	
	Blue(1)	0	0	0	0	0	0	0	0	0	0	0	0	0	0	0	0	0	0	0	0	0	0	1	
	Blue(2)	0	0	0	0	0	0	0	0	0	0	0	0	0	0	0	0	0	0	0	0	0	0	1	
	:	:	:	:	:	:	:	:	:	:	:	:	:	:	:	:	:	:	:	:	:	:	:	:	
	:	:	:	:	:	:	:	:	:	:	:	:	:	:	:	:	:	:	:	:	:	:	:	:	
	Blue(253)	0	0	0	0	0	0	0	0	0	0	0	0	0	0	0	0	1	1	1	1	1	1	0	
	Blue(254)	0	0	0	0	0	0	0	0	0	0	0	0	0	0	0	0	1	1	1	1	1	1	0	
Blue(255)	0	0	0	0	0	0	0	0	0	0	0	0	0	0	0	0	1	1	1	1	1	1	1		

Note (1) 0: Low Level Voltage, 1: High Level Voltage

6. INTERFACE TIMING

6.1 INPUT SIGNAL TIMING SPECIFICATIONS

The input signal timing specifications are shown as the following table and timing diagram.

Signal	Item	Symbol	Min.	Typ.	Max.	Unit	Note
LVDS Clock	Frequency	Fc	50	59.5	82	MHz	-
	Period	Tc	13.4	16.8	-	ns	-
	High Time	Tch	-	4/7	-	Tc	-
	Low Time	Tcl	-	3/7	-	Tc	-
LVDS Data	Setup Time	Tlvs	600	-	-	ps	-
	Hold Time	Tlvh	600	-	-	ps	-
Vertical Active Display Term	Frame Rate	Fr	50	60	76	Hz	$T_v = T_{vd} + T_{vb}$
	Total	Tv	1060	1080	1195	Th	-
	Display	Tvd	1050	1050	1050	Th	-
	Blank	Tvb	$T_v - T_{vd}$	30	$T_v - T_{vd}$	Th	-
Horizontal Active Display Term	Total	Th	890	920	1000	Tc	$T_h = T_{hd} + T_{hb}$
	Display	Thd	840	840	840	Tc	-
	Blank	Thb	$T_h - T_{hd}$	80	$T_h - T_{hd}$	Tc	-

Note : (1) Because this module is operated by DE only mode, Hsync and Vsync input signals should be set to low logic level or ground. Otherwise, this module would operate abnormally.

INPUT SIGNAL TIMING DIAGRAM

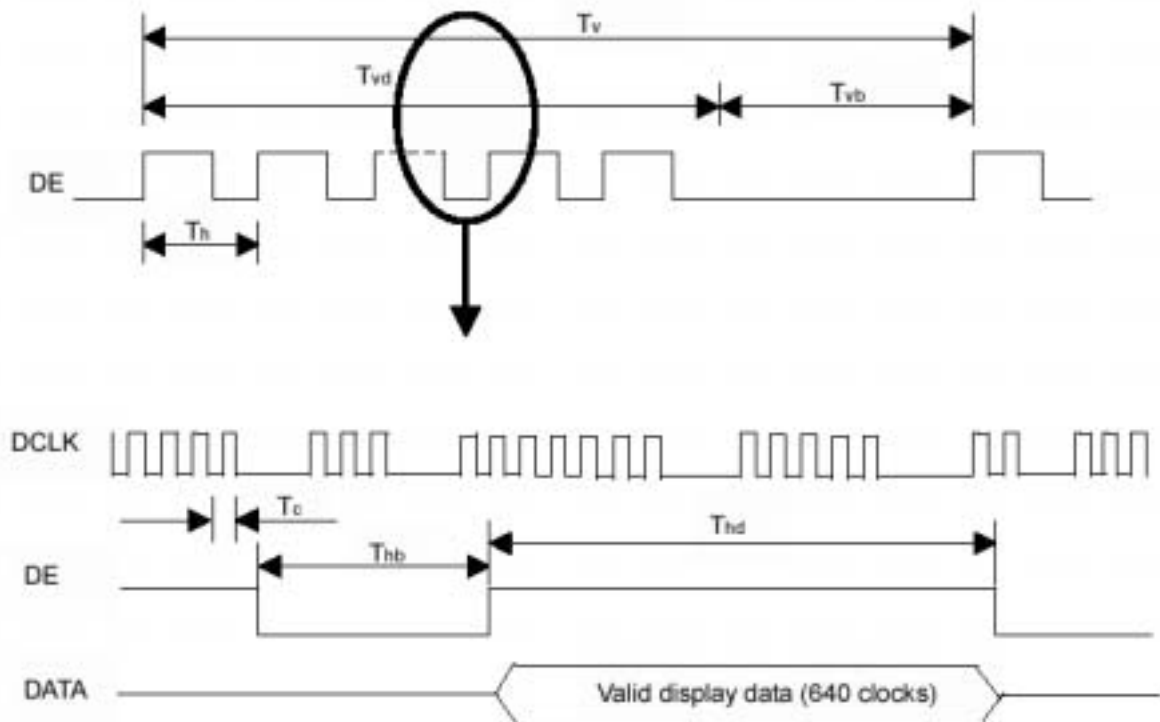

6.2 POWER ON/OFF SEQUENCE

To prevent a latch-up or DC operation of LCD module, the power on/off sequence should be as the diagram below.

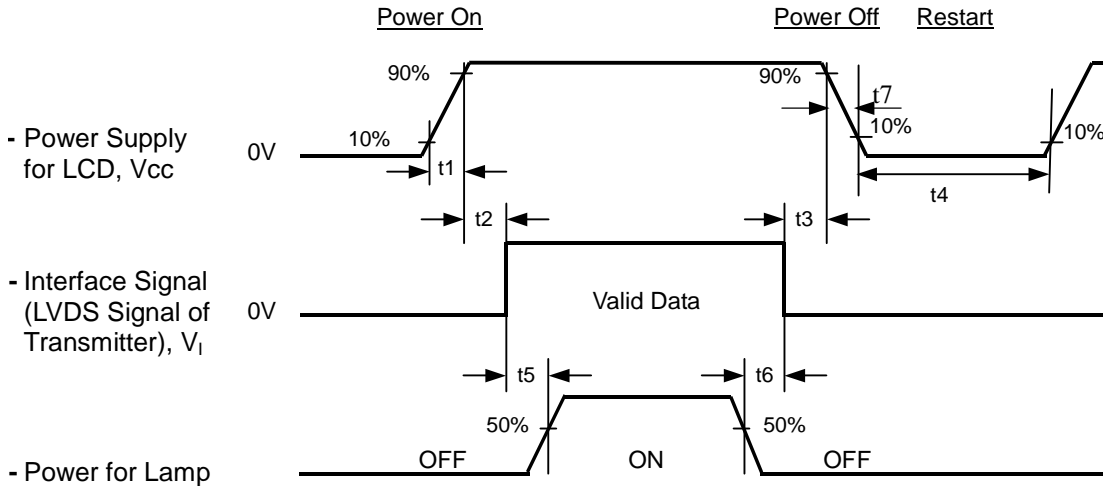

Timing Specifications:

0.5 < t ₁	10 msec
0 < t ₂	50 msec
0 < t ₃	50 msec
t ₄	500 msec
t ₅	450 msec
t ₆	90 msec
5 t ₇	100 msec

Note :

- (1) The supply voltage of the external system for the module input should be the same as the definition of V_{cc}.
- (2) Apply the lamp voltage within the LCD operation range. When the backlight turns on before the LCD operation of the LCD turns off before the backlight turns off, the display may momentarily become abnormal screen.
- (3) In case of V_{CC} = off level, please keep the level of input signals on the low or keep a high impedance.
- (4) T₄ should be measured after the module has been fully discharged between power off and on period.
- (5) Interface signal shall not be kept at high impedance when the power is on.
- (6) The company will not guarantee or compensate for the product damage caused by not following the Power Sequence.

7. OPTICAL CHARACTERISTICS

7.1 TEST CONDITIONS

Item	Symbol	Value	Unit
Ambient Temperature	Ta	25±2	°C
Ambient Humidity	Ha	50±10	%RH
Supply Voltage	V _{CC}	5.0	V
Input Signal	According to typical value in "3. ELECTRICAL CHARACTERISTICS"		
Inverter Current	I _L	7.5	mA
Inverter Driving Frequency	F _L	55	KHz
Inverter	Logah MIT70070.50		

7.2 OPTICAL SPECIFICATIONS

The relative measurement methods of optical characteristics are shown in 7.2. The following items should be measured under the test conditions described in 7.1 and stable environment shown in Note (6).

Item	Symbol	Condition	Min.	Typ.	Max.	Unit	Note	
Color Chromaticity	Red	Rx	$\theta_x=0^\circ, \theta_y=0^\circ$ CS-1000T R=G=B=255 Grayscale	Typ - 0.03	0.649	Typ + 0.03	(1), (5)	
		Ry			0.335			
	Green	Gx			0.283			
		Gy			0.605			
	Blue	Bx			0.151			
		By			0.073			
	White	Wx			0.313			
		Wy			0.329			
Center Luminance of White	L _C		200	250	---	cd/m ²	(4), (5)	
Contrast Ratio	CR		700	1000	---	-	(2), (6)	
Response Time	T _R	$\theta_x=0^\circ, \theta_y=0^\circ$	---	1.3	2.2	ms	(3)	
	T _F		---	3.7	5.8	ms		
White Variation	δW	$\theta_x=0^\circ, \theta_y=0^\circ$	---	---	1.33	-	(5), (6)	
Viewing Angle	Horizontal	θ _{x+}	CR>10 USB2000	75	85	---	Deg.	(1), (5)
		θ _{x-}		75	85	---		
	Vertical	θ _{y+}		70	80	---		
		θ _{y-}		70	80	---		

Note (1) Definition of Viewing Angle (θ_x, θ_y):

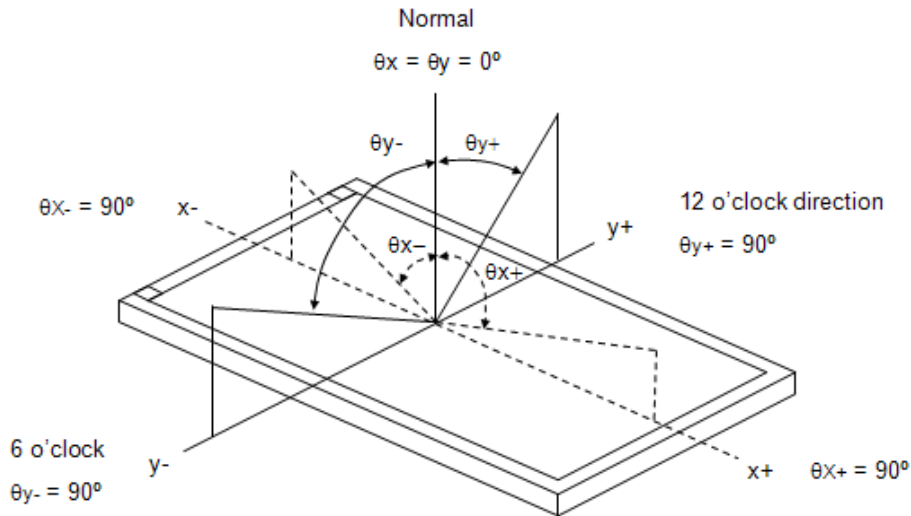

Note (2) Definition of Contrast Ratio (CR):

The contrast ratio can be calculated by the following expression.

$$\text{Contrast Ratio (CR)} = L_{255} / L_0$$

L255: Luminance of gray level 255

L 0: Luminance of gray level 0

$$\text{CR} = \text{CR} (5)$$

CR (X) is corresponding to the Contrast Ratio of the point X at Figure in Note (6).

Note (3) Definition of Response Time (T_R, T_F):

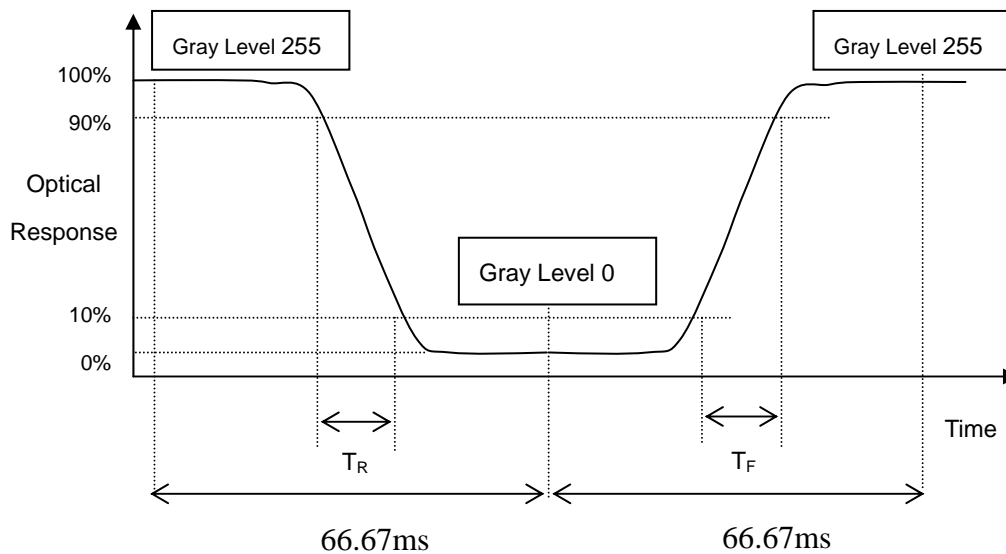

Note (4) Definition of Luminance of White (L_C):

Measure the luminance of gray level 255 at center point

$$L_C = L(5)$$

$L(x)$ is corresponding to the luminance of the point X at Figure in Note (6).

Note (5) Measurement Setup:

The LCD module should be stabilized at given temperature for 20 minutes to avoid abrupt temperature change during measuring. In order to stabilize the luminance, the measurement should be executed after lighting Backlight for 20 minutes in a windless room.

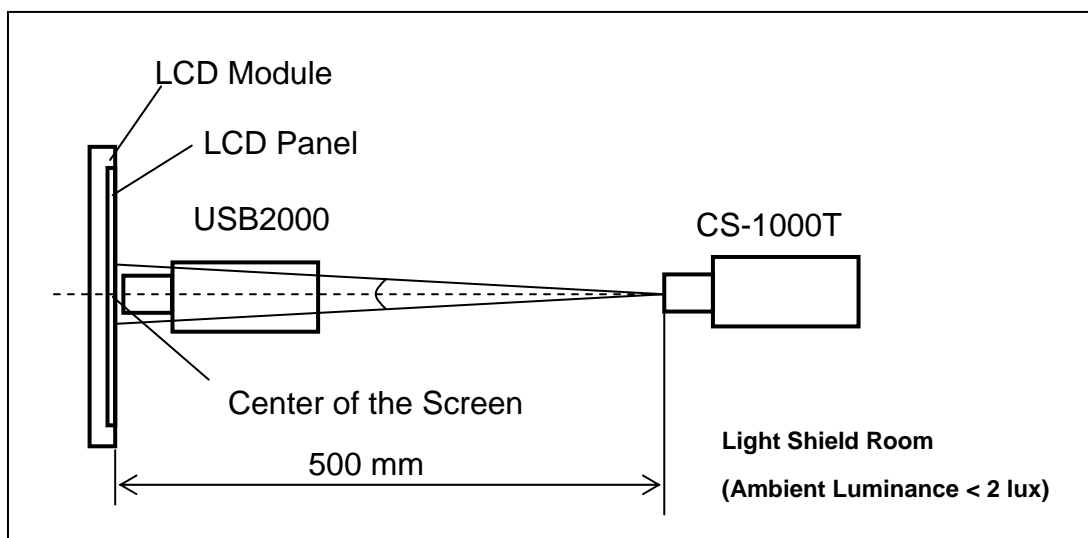

Note (6) Definition of White Variation (δW):

Measure the luminance of gray level 255 at 9 points

$$\delta W = \text{Maximum} [L(1) \sim L(9)] / \text{Minimum} [L(1) \sim L(9)]$$

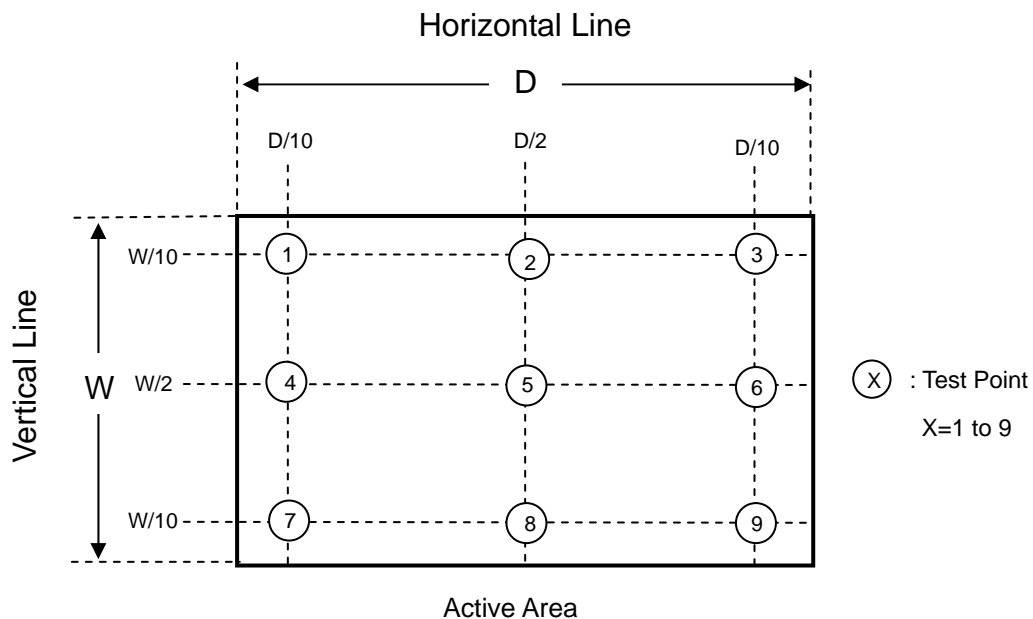

8. PACKAGING

8.1 PACKING SPECIFICATIONS

- (1) 8 LCD modules / 1 Box
- (2) Box dimensions: 570(L) X 300 (W) X 430 (H) mm
- (3) Weight: 25.41 Kg (8 modules per box)

8.2 PACKING METHOD

- (1) Carton Packing should have no failure in the following reliability test items.

Test Item	Test Conditions	Note
Vibration	ISTA STANDARD Random, Frequency Range: 1 – 200 Hz Top & Bottom: 30 minutes (+Z), 10 min (-Z), Right & Left: 10 minutes (X) Back & Forth 10 minutes (Y)	Non Operation
Dropping Test	1Corner, 3 Edge, 6 Face, ISTA STANDARD	Non Operation

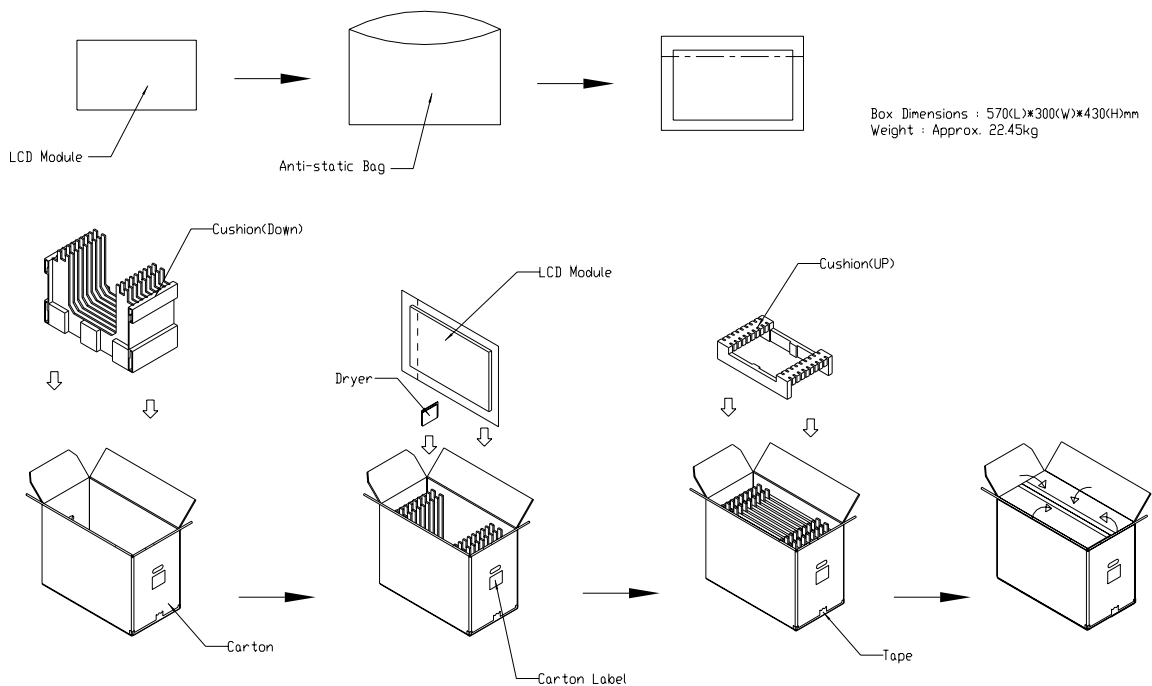
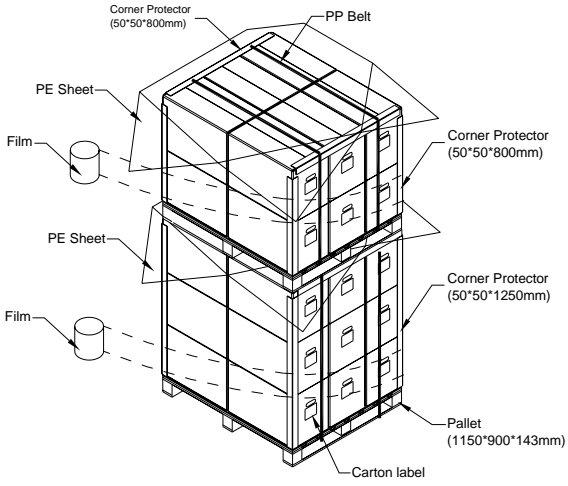

Figure. 8-1 Packing method

Sea/Land Transportation

Sea / Land Transportation (40ft HQ Container)



Sea / Land Transportation (40ft Container)

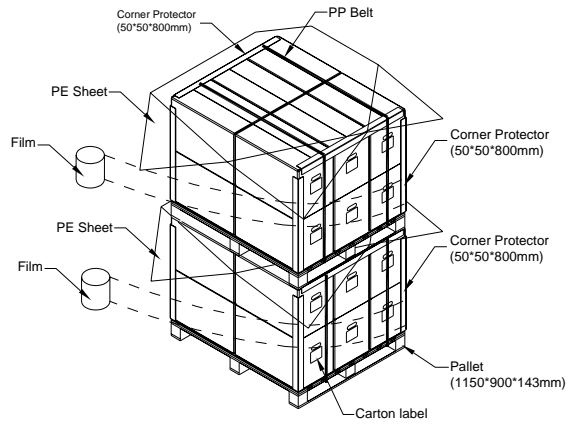

Air Transportation

Air Transportation

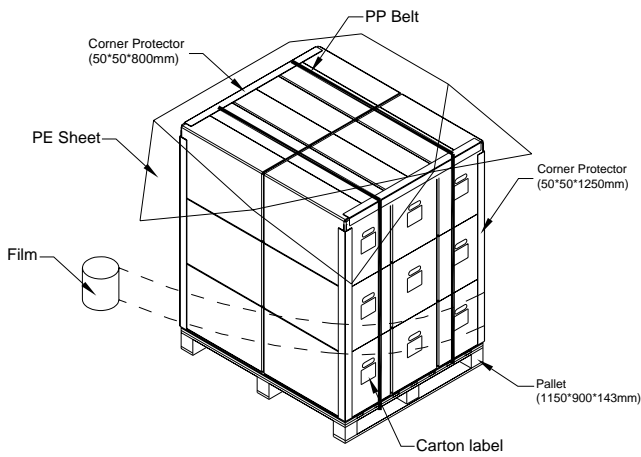

Figure. 8-2 Packing method

Figure. 8-3 Packing method

9. DEFINITION OF LABELS

9.1 CMO MODULE LABEL

The barcode nameplate is pasted on each module as illustration, and its definitions are as following explanation.



- (a) Model Name: M220Z1-L10
- (b) Revision: Rev. XX, for example: A0, A1... B1, B2... or C1, C2...etc.
- (c) CMO barcode definition:

Serial ID: XX-XX-X-XX-YMD-L-NNNN

Code	Meaning	Description
XX	CMO internal use	-
XX	Revision	Cover all the change
X	CMO internal use	-
XX	CMO internal use	-
YMD	Year, month, day	Year: 2001=1, 2002=2, 2003=3, 2004=4... Month: 1~12=1, 2, 3, ~, 9, A, B, C Day: 1~31=1, 2, 3, ~, 9, A, B, C, ~, W, X, Y, exclude I, O, and U.
L	Product line #	Line 1=1, Line 2=2, Line 3=3, ...
NNNN	Serial number	Manufacturing sequence of product

- (d) Customer's barcode definition:

Serial ID: CM-22Z10-X-X-X-XX-L-XX-L-YMD-NNNN

Code	Meaning	Description
CM	Supplier code	CMO=CM
22Z10	Model number	M220Z1-L10=22Z10
X	Revision code	ZBD: A~Z Non ZBD: 1,2,~,8,9
X	Source driver IC code	Century=1, CLL=2, Demos=3, Epson=4, Fujitsu=5, Himax=6, Hitachi=7, Hynix=8, LDI=9, Matsushita=A, NEC=B, Novatec=C, OKI=D, Philips=E, Renasas=F, Samsung=G, Sanyo=H, Sharp=I, TI=J, Topro=K, Toshiba=L, Windbond=M
X	Gate driver IC code	
XX	Cell location	Tainan, Taiwan=TN
L	Cell line #	1,2,~,9,A,B,~,Y,Z
XX	Module location	Tainan, Taiwan=TN; Ningbo China=NP
L	Module line #	1,2,~,9,A,B,~,Y,Z
YMD	Year, month, day	Year: 2001=1, 2002=2, 2003=3, 2004=4... Month: 1~12=1, 2, 3, ~, 9, A, B, C Day: 1~31=1, 2, 3, ~, 9, A, B, C, ~, T, U, V
NNNN	Serial number	By LCD supplier



(e) UL Factory ID:

Region	Factory ID
TWCMO	GEMN
NBCMO	LEOO
NBCME	CANO
NHCMO	CAPG

10. PRECAUTIONS

10.1 ASSEMBLY AND HANDLING PRECAUTIONS

- (1) Do not apply rough force such as bending or twisting to the module during assembly.
- (2) To assemble or install module into user's system can be only in clean working areas. The dust and oil may cause electrical short or worsen the polarizer.
- (3) It's not permitted to have pressure or impulse on the module because the LCD panel and Backlight will be damaged.
- (4) Always follow the correct power sequence when LCD module is connecting and operating. This can prevent damage to the CMOS LSI chips during latch-up.
- (5) Do not pull the I/F connector in or out while the module is operating.
- (6) Do not disassemble the module.
- (7) Use a soft dry cloth without chemicals for cleaning, because the surface of polarizer is very soft and easily scratched.
- (8) It is dangerous that moisture come into or contacted the LCD module, because moisture may damage LCD module when it is operating.
- (9) High temperature or humidity may reduce the performance of module. Please store LCD module within the specified storage conditions.
- (10) When ambient temperature is lower than 10°C may reduce the display quality. For example, the response time will become slowly, and the starting voltage of CCFL will be higher than room temperature.

10.2 SAFETY PRECAUTIONS

- (1) The startup voltage of Backlight is approximately 1000 Volts. It may cause electrical shock while assembling with inverter. Do not disassemble the module or insert anything into the Backlight unit.
- (2) If the liquid crystal material leaks from the panel, it should be kept away from the eyes or mouth. In case of contact with hands, skin or clothes, it has to be washed away thoroughly with soap.
- (3) After the module's end of life, it is not harmful in case of normal operation and storage.

10.3 SAFETY STANDARDS

The LCD module should be certified with safety regulations as follows:

- (1) UL60950-1 or updated standard.
- (2) IEC60950-1 or updated standard.

10.4 OTHER

When fixed patterns are displayed for a long time, remnant image is likely to occur.

1 2 3 4 5 6 7 8 9 10 11 12 13 14 15 16

A
B
C
D
E
F
G
H

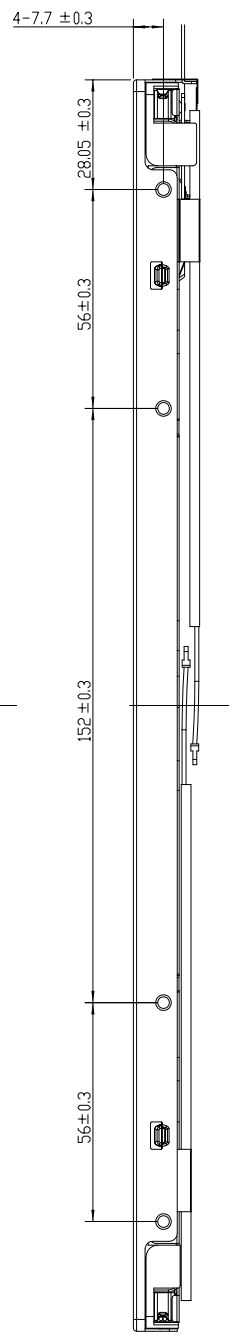
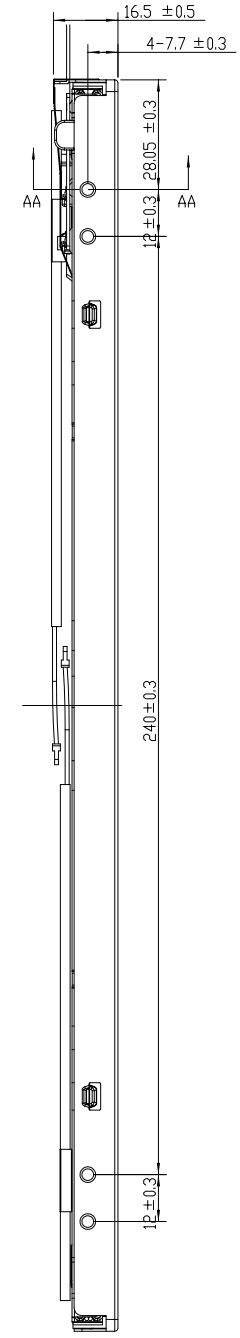
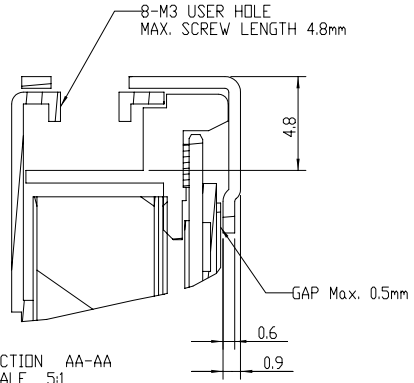

NOTES:
 1. OUTLINE TOLERANCE: ±0.5mm.
 2. I/F CONNECTOR SPEC: STARCONN (093G30-B0001A) or STM (MSAKT2407P30HA).
 3. LAMP CONNECTOR: JST BHSR-02VS-1.
 4. SIDE MOUNT HOLE ROTATIONAL TORQUE MUST BE MAX. 5kgf-cm.

TITLE		ASSY_MODULE_M22021_L10 (SECC)		2D REV. A	
Approved		YULE_LIN		3D REV. 1.0	
Checked		TIGER_CHANG		Drawing No. M22014126A	
Designer		AIDEN_WAN		Part No. TBD	
Date		2008-11-21		Material TBD	
Scale		1:1		Sheet 1 / 2	
Unit		mm		A1	
		CHI MEI OPTOELECTRONICS CORP.		ALL RIGHTS RESERVED. COPYING FORBIDDEN.	

Mark	Description	Date	Changed_By	Approved_By	ECN No.	Remark

1 2 3 4 5 6 7 8 9 10 11 12 13 14 15 16

CONNECTOR: YEDNHD 35001HS-02L
CONNECTOR 1: PIN1-PINK
PIN2-WHITE
CONNECTOR 2: PIN1-BLUE
PIN2-BLACK

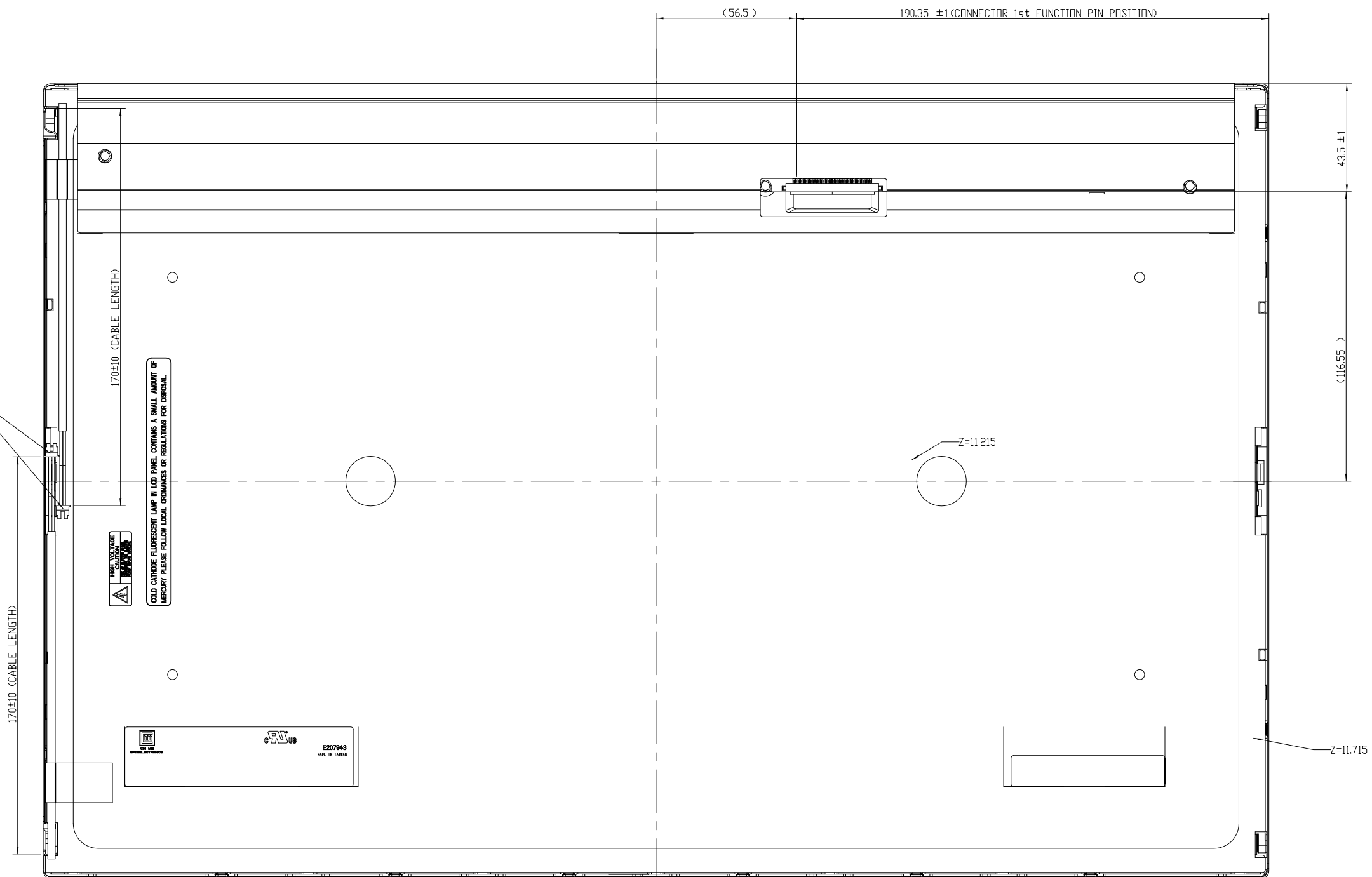

NOTES:
1. OUTLINE TOLERANCE: ±0.5mm.
2. I/F CONNECTOR SPEC: STARCONN (093G30-B0001A) or STM (MSAKT2407P30HA).
3. LAMP CONNECTOR: JST BHSR-02VS-1.
4. SIDE MOUNT HOLE ROTATIONAL TORQUE MUST BE MAX. 5kgf-cm.

TITLE		ASSY_MODULE_M22021_L10 (SECC)		2D REV. A	
Approved		YULE_LIN		3D REV. 1.0	
Checked		TIGER_CHANG		Drawing No. M22014126A	
Drawer		AIDEN_WAN		Part No. TBD	
Designer		AIDEN_WAN		Material TBD	
Date		2008-11-21		Sheet 2 / 2	
Scale		1:1		Unit:mm	
Unit:mm		1:1		A1	
CHI MEI		ALL RIGHTS RESERVED. COPYING FORBIDDEN.			
OPTOELECTRONICS CORP.					

Mark	Description	Date	Changed_By	Approved_By	ECN No.	Remark
1						
2						
3						
4						